

BUILDING

1. (p.1) All storm shelters now require permits.
2. (p.1) Common wall rating applicable when it is also the LL.
3. (p.4) 10-ml. barrier is required for this edition—check local amendments.
4. (p.4) Vents to be near external corners—previous edition said all corners. A new exception also exempts these if cross-ventilation is provided.
5. (p.6) BWPs can no longer be entirely on one side of the BWL.
6. (p.6) Sheathing no longer required on interior cripple walls.
7. (p.7) The 2018 IRC allowed the use of collar ties or ridge straps in lieu of a ridge board. The 2021 edition requires either (1) a gusset or (2) a ridge board with collar ties or ridge straps.
8. (p.7) Specification that ridge straps be min 1¼×20 ga., 3 nails each rafter.
9. (p.8) Allowance for long ties to attach to WSP, not necessarily to studs.
10. (p.9) 6-in. O/C field nailing now if sheathing ≤¾ in.
11. (p.10) New tables added for snow loads on decks.
12. (p.10) Wood supports exposed to weather must be PT or NDW.
13. (p.10) Clarification on stairways that are not within the scope of the code.
14. (p.10) Changed from 12 ft. 4 in. (148 in.) in previous edition.
15. (p.11) Live load design for guards that are not hand-ails now considered only in vertical downward direction or horizontally away from walking surface.
16. (p.11) Height now measured to actual opening, not to height of sill.
17. (p.11) Allowance for smaller openings for additions or change of use.
18. (p.11) Rise and run of area well stairs was not previously defined.
19. (p.12) The door must now be self-latching as well as self-closing.
20. (p.12) Kitchen windows exempt from being openable if local exhaust provided.
21. (p.12) Allowance for height to beams is same as height for egress door.
22. (p.13) Garage doors now require manufacturer's label.
23. (p.14) Prior code exempted repairs for plumbing & mechanical; 2021 now requires CO alarms when such work involves fuel-fired appliances.
24. (p.14) Listing and marking referred to in F25 is new and now mandatory.

PLUMBING

25. (p.15) The 2018 IRC required only a 5-ft. head for DWV rough-in.
26. (p.16) The UPC allows an existing 1½-in. drain for a tub if converting to a shower. May contradict the requirement for a 2-in. area drain strainer.
27. (p.16) Former limit was 3-in. pipe to 4 WCs on vertical drain, 3 on horizontal.
28. (p.16) Explicitly allows a commonly followed standard practice.
29. (p.18) Could be applied to prohibit air-chamber water hammer arresters.
30. (p.20) TPRV drain must terminate in observable location.
31. (p.21) Previous editions required sediment trap upstream of flex connector.
32. (p.21) Added clarity regarding arc-resistant jacketed & coated systems.

MECHANICAL

33. (p.23) Wye or tee fittings can no longer be fabricated in the field.
34. (p.23) The IRC removed the exemption for lining of existing chimneys that have passed inspection; all chimneys venting gas appliances must be lined. The UMC still allows the exemption if chimney passes inspection.
35. (p.24) Rule for securing within 6 ft. new to this IRC edition.
36. (p.24) The UMC has adopted several ventilation requirements consistent with energy codes and ASHRAE 62.2.

ELECTRICAL

37. (p.25) No longer allows exception to barrier rule for 2-6 disconnects.
38. (p.25) Each service enclosure requires a single main disconnect.
39. (p.25) An exterior emergency disconnect required for first responders.
40. (p.25) New or replacement services now require a surge-protective device.
41. (p.26) Explicit rule that panelboards may not be in face-up position.
42. (p.26) Means other than calibrated torque test may be approved locally.
43. (p.26) Ufer cannot be used to interconnect other GECs.
44. (p.27) In addition to the required 20A circuit recepts near the sink, other recep outlets are allowed and do not need to be on 20A circuits.
45. (p.27) Other garage outlets, such as for vehicle door openers, not allowed to be on the required 20A circuit for recepts in each vehicle bay.
46. (p.27) All countertop recepts can be on the side of a cabinet in this edition. *In the next (2023) edition, no required outlets are on the side of a cabinet.*
47. (p.27) This edition expanded the required locations of these recepts. The next edition will not require any, other than infrastructure for future outlets.
48. (p.27) This zone now excludes recep outlets unless the room is <3 ft. wide, in which case the outlet goes on the opposite wall of the tub/shower.
49. (p.27) Previously only applied to attached decks or balconies.
50. (p.28) Now applies to all recepts rated 250V, such as clothes dryers if located in an area, such as a laundry room, where recepts require GFCI.
51. (p.28) Now applies to all basement recepts, not just unfinished basements.
52. (p.28) The 6-ft. measurement now includes a cord passing through a door, such as the cabinet door in front of a food-waste grinder.
53. (p.28) The 6-ft. distance is now the conductor distance between enclosures; it does not include the wiring within the enclosures.
54. (p.28) DW cords passing through cabinet require a protective grommet.
55. (p.28) Boxes in areas w/ potential use as paddle fan require listed fan boxes. Previous requirement was to include a control conductor.
56. (p.28) GFCI protection now required. If adopted locally, a temporary amendment delays implementation of this rule to September 2026.
57. (p.28) New requirement that all switches be listed.
58. (p.29) When a conductor forms a loop or is otherwise not straight between the box and the nearest support, the max conductor length is 18 in.
59. (p.29) Clarification that a pull-down ladder is not a stair for this rule.
60. (p.30) Appliances <¼ hp are part of general lighting load & are not counted as separate appliances for load calculation purposes.
61. (p.30) The first 4 EGCs count as one volume allowance based on the largest EGC; a ¼-volume allowance is required for each additional EGC.
62. (p.30) Replacement pool pump motors require GFCI protection.

For codes, commentaries, and further analysis of changes in this cycle, see <https://codes.iccsafe.org>.

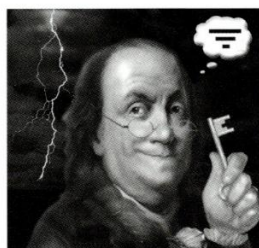

Benjamin Franklin was chosen as the main character in our illustrations for a number of reasons. His insatiable curiosity, scientific genius, and civic-mindedness drove him to promote fire safety, public sanitation, heating methods that improved efficiency and reduced pollution, safe exits, and, of course, electricity. Franklin made major contributions to each of the four main disciplines of building inspection: Building, Plumbing, Mechanical, and Electrical.

PERMITS & INSPECTIONS

Permits

21 IRC

- Permits required for all work EXC _____ 105.1
 - Fences ≤ 7 ft. high
 - Retaining walls ≤ 4 ft. from bottom of footing to top of wall & no surcharge
 - Water tanks on grade $\leq 5,000$ gallons & $\leq 2:1$ aspect ratio
 - Sidewalks, driveways, painting, countertops, similar finish work
 - Wall-supported window awnings ≤ 54 in. projection
 - Pre-fab pools < 24 in. deep
 - Detached accessory structures ≤ 200 sq. ft. floor area exc storm shelters
 - Decks ≤ 200 sq. ft. & ≤ 30 in. above grade & not attached to dwelling & not serving required exit door _____ 105.2¹
- Approved plans & permit card must be on job site _____ 106.3.1
- Inspection & approval prior to covering any work _____ 109.4

DWELLING UNIT SEPARATION

Townhouse Units

21 IRC

- Townhouse units must be open to yard or public way on at least 2 sides _____ 202
- Townhouse unit vertical separation either two 1-hour walls or one 2-hour wall (one 1-hour wall if fire protected by sprinkler system) _____ 302.2
- Each townhouse unit structurally independent if 2 1-hour walls EXC _____ 302.2.6
 - When protected by fire sprinkler system
- Parapets not required if no roof openings within 4 ft. each side of separation wall, roof covering min. Class C & sheathing noncombustible or fire-retardant min. 4 ft. each side or min. $\frac{5}{8}$ -in. Type X GB on 2×2 ledgers _____ 302.2.4X

2-Family Dwellings

- 1-hour separation vertical & horizontal between units EXC _____ 302.3
 - $\frac{1}{2}$ -hour if sprinklered _____ 302.3X1
 - Attic draftstopping separation if both ceilings $\frac{5}{8}$ -in. Type X GB _____ 302.3X2
- Separation required even if LL exists between the 2 units _____ 302.3²
- Supporting construction below rated floor/ceiling assemblies requires rating no less than the rating of the floor/ceiling assembly _____ 302.3.1

BUILDING LOCATION

Setbacks (Fire Separation Distance) F1

21 IRC

- Verify setbacks—unrated walls min 5 ft. to LL EXC _____ T302.1(1)
 - 3 ft. OK if sprinklered _____ T302.1(2)
 - Walls perpendicular to the line that determines the FSD _____ 302.1X1
 - Individual dwellings & their accessory structures on same lot _____ 302.1X2
 - Accessory structures that are exempt from permits _____ 302.1X3
- No openings in walls < 3 ft. to LL EXC _____ T302.1(1&2)
 - Foundation vents OK _____ 302.1X5
- Openings up to 25% of wall area OK ≥ 3 ft. & < 5 ft. EXC _____ T302.1(1)
 - Unlimited openings ≥ 3 ft. if sprinklered _____ T302.1(2)
- Unrated projections min 5 ft. FSD EXC _____ T302.1(1)
 - 3 ft. OK unrated if sprinklered _____ T302.1(2)
 - 2 ft. OK if 1-hour protected on underside _____ T302.1(1&2)
 - 2 ft. OK unprotected if fireblocked top plate to roof & no gable vent T302.1(1&2)
 - Projections ≤ 4 in. allowed for detached garages within 2 ft. of LL _____ 302.1X4

FIG. 1

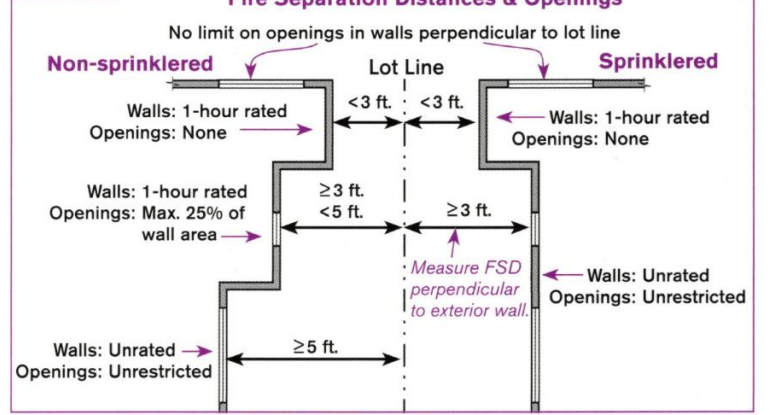

BUILDING PERMITS ◆ DWELLING UNIT SEPARATION ◆ BUILDING LOCATION

1

FOUNDATION ANCHORAGE

Plates & Sills

21 IRC

- Sill PT or decay resistant if < 8 in. above exposed ground _____ 317.1#2
- PT wood fasteners (including nails, nuts & washers) hot-dipped galv min G185 HDG coating, SS, silicone bronze, or Cu EXC _____ 317.3.1
 - Bolts $\geq \frac{1}{2}$ in. diameter _____ 317.3.1X1
 - Plain carbon steel OK in Zinc-Borate treated wood in dry interior 317.3.1X3

Anchor Bolts F4

- Required for all sills & for exterior wall sole plates of monolithic slabs _____ 403.1.6
- Required for interior BWPs on monolithic slabs _____ 403.1.6
- Embed bolts min 7 in. in concrete or grouted cell of CMUs _____ 403.1.6
- Max spacing 6 ft. O.C. & min 2 bolts per plate EXC _____ 403.1.6
 - Walls ≤ 24 in. connecting offset BWs 1 bolt in center $\frac{1}{3}$ _____ 403.1.6X1
 - Walls ≤ 12 in. connecting offset BWs no bolts required _____ 403.1.6X1
- Max 12 in. & min 7 bolt diameter from end of sill, middle $\frac{1}{3}$ of width _____ 403.1.6
- SDC D & Light-frame Townhouses in SDC C: _____ 403.1.6.1
 - Bolts at all interior BWP plates & interior bearing wall sole plates _____ 403.1.6.1
 - Min 0.229 in. \times 3-in. \times 3-in. plate washers all BWs _____ 403.1.6.1 & 602.11.1
 - Max spacing 4 ft. O.C. for over 2 stories _____ 403.1.6.1

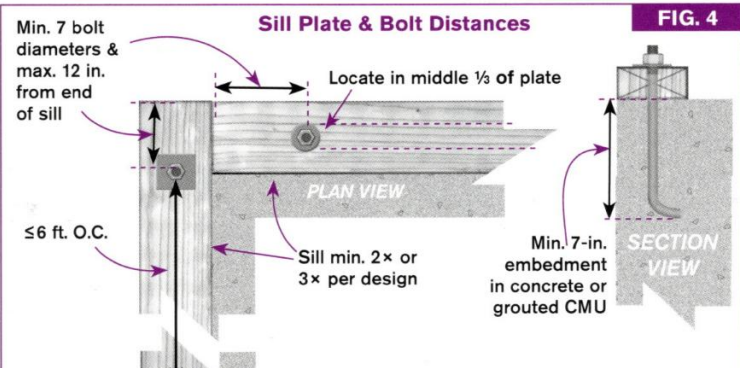

BASEMENT & FOUNDATION WALLS

General

21 IRC

- CMU walls min $\frac{5}{8}$ -in. parge prior to dampproofing EXC _____ 406.1
 - Dampproofing materials approved for direct application F3 _____ 406.1X
- No unbalanced backfill > 4 ft. until walls anchored to floor _____ 404.1.7
- Walls subject to hydrostatic pressure or supporting > 4 ft. of backfill w/o lateral restraint at top or bottom require engineered design _____ 404.1.1
- CMU rebar min distance from soil T1, F3 _____ 404.1.2.1

TABLE 1 CMU REBAR DISTANCE FROM SOIL ◆ T404.1.1(2,3,4)

Thickness of masonry foundation wall	8 in.	10 in.	12 in.
Min distance face of soil to center of rebar	5 in.	6 $\frac{3}{4}$ in.	8 $\frac{3}{4}$ in.

CONCRETE & REINFORCEMENT

General

21 IRC

- Min 2,500 psi in SDC A, B, or C; 3,000 psi in SDC D _____ 404.1.3.3.1
- Max slump 6 in. for concrete in removable forms _____ 404.1.3.3.4
- Work into corners & around embedded items _____ 404.1.3.3.5

Rebar—General

- Clearance to forms & soil T2 _____ 404.1.3.3.7.4
- Splice laps (grade 60) min 30 in. #4; 38 in. #5; 45 in. #6 _____ 404.1.3.3.7.5
- Max gap between parallel lapped bars 6 in. & $\frac{1}{5}$ splice length _____ 404.1.3.3.7.5

Rebar in SDC D

- Footings min 1 #4 horizontal bar 3–4 in. from bottom _____ 403.1.3.1&2
- Min 1 #4 horizontal bar within 12 in. of top of stem wall _____ 403.1.3.1&2
- Vertical bars 4 ft. O.C. if construction joint between footing & stem wall or between footing & grouted CMU wall _____ 403.1.3.1&2
- Slab w/ turned-down footing reinforcement per F5 _____ 403.1.3.3

TABLE 2 REINFORCING STEEL COVER ◆ 404.1.3.3.7.4

Foundation Surface	Min. Cover \leq #5 bars	Min. Cover \geq #6 bars
Cast against & permanently exposed to earth	3 in.	3 in.

SOILS & GRADING

Soils, Grading & Drainage

21 IRC

- Expansive soil requires design per IBC 1808.6 or waiver by AHJ ___ 403.1.8
- Trenching parallel to footings must remain outside of the undisturbed soil within 45° down & out from the bottom edge of the footing **F3,27** 2604.4
- Drain system required for foundations enclosing usable space below grade unless well-drained ground or sand/gravel mixture **F3** ___ 405.1
- Provide dampproofing to finished grade for walls retaining earth & enclosing interior space **F3** (waterproofing if high water table exists) 406.1&2
- Grading from foundation min 6 in. fall in first 10 ft. **EXC F2** ___ 401.3
 - Use drains or swales when lot lines, walls, etc. prevent 6 in./10 ft. ___ 401.3X
- Hardscape min 2% slope away from building within 10 ft. **F2** ___ 401.3X
- Top of foundation min. 12 in. + 2% slope above street gutter ___ 403.1.7.3
- If soils expansive, roof drain must discharge min 5 ft. from foundation ___ 801.3

FIG. 2

Site Grading

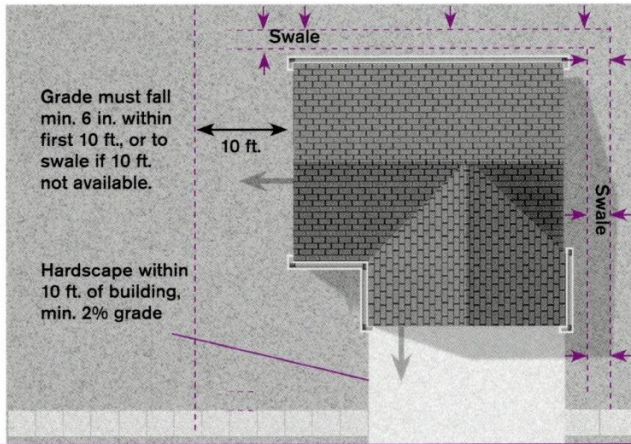

FOOTINGS & FOUNDATIONS

General

21 IRC

- Top surface of footings must be level ___ 403.1.5
- Foundation min 6 in. above earth (4 in. if masonry veneer used) ___ 404.1.6
- Max slope bottom of footing 1:10—must be stepped if > 1:10 ___ 403.1.5
- Min footing thickness 6 in., min footing projection 2 in. ___ 403.1.1
- Footing width & thickness per T403.1, min 12 in. width ___ 403.1.1
- Footings min 12 in. below undisturbed ground surface **F3** ___ 403.1.4
- Extend footings below frost line or provide frost protection ___ 403.1.4.1
- Excavation free of organic material & wood forms removed ___ 408.5 & 506.2
- Min 1/2-in. air space at ends & sides of untreated wood beam pockets 317.1#4

FIG. 3

Basement Walls

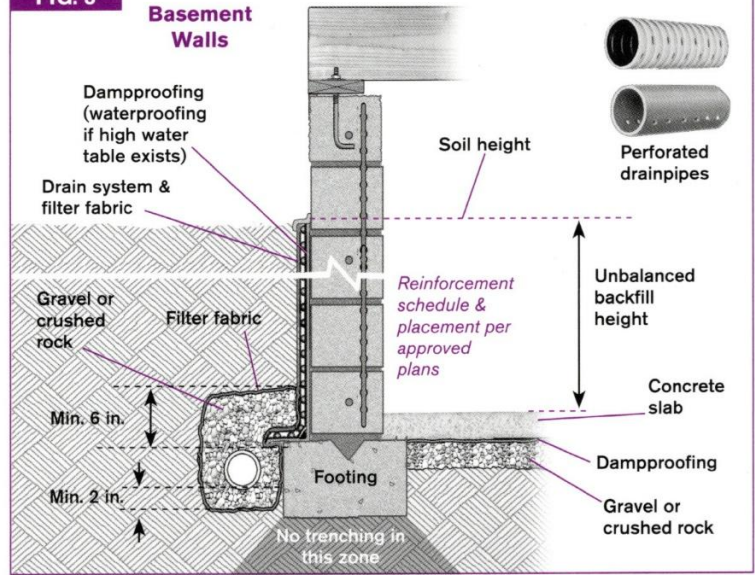

CONCRETE SLABS

Concrete Slabs F5

21 IRC

- Remove vegetation & foreign material prior to casting concrete floor ___ 506.2
- Slab on grade floors min 3 1/2 in. thick ___ 506.1
- Min 4-in. base course if below grade unless well-drained soils ___ 506.2.2
- Where reinforcement is installed, support it in the center to upper 1/3 of the slab during concrete placement ___ 506.2.4
- Min 10-mil polyethylene or vapor retarder lapped min 6 in. **EXC** ___ 506.2.3³
 - May be omitted at detached garages, driveways, patios, etc. ___ 506.2.3X
- Moderate weathering potential exposed slabs & garage slabs min 3,000 psi air-entrained concrete (severe weathering 3,500) ___ T402.2

FIG. 5

Monolithic Slab with Footings

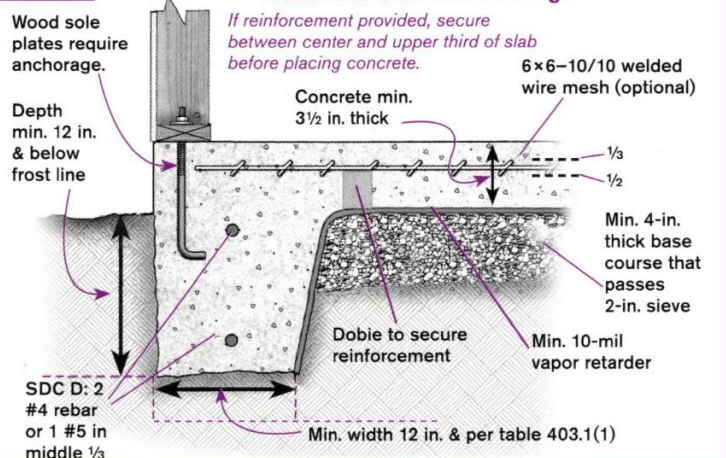

CONCRETE MASONRY UNITS (CMU)

General

21 IRC

Grout

21 IRC

- Cells containing reinforcement require solid grout fill ___ 606.3.5.3
- Cleanouts required for pours >64 in. ___ 606.3.5.2
- Max pour heights & grout joints ___ T606.3.5.1
- Grout pours >8 ft. placed in lifts & special inspection required ___ 606.3.5.1

UNDERFLOOR SPACE

Prep and Forms

21 IRC

- Remove all form material (except ICF) & organic or other debris ___ 408.5

Access Openings

- Floor openings min 18 in. x 24 in. ___ 408.4
- Wall openings min 24 in. wide x 16 in. high ___ 408.4
- Access opening not allowed in wall below a door ___ 408.4
- If appliance present, opening to allow removal & min 22 in. x 30 in. 1305.1.3

Ventilation & Moisture Control

- Ventilated crawlspace:
 - One vent opening within 3 ft. of each external corner **F6** ___ 408.1&2⁴
 - Openings screened or grated, least opening dimension 1/4 in. ___ 408.2
 - Min area 1 sq. ft. per 150 sq. ft. of underfloor area ___ 408.1&2
 - Reduction to 1/1500 OK w/ Class 1 vapor retarder ___ 408.1 & 408.2X
- Unvented crawlspace within BTE:
 - Class I vapor retarder on ground & stem walls ___ 408.3
 - Mechanical ventilation, conditioned supply, or dehumidification ___ 408.3

FIG. 6

Ventilated Crawlspace

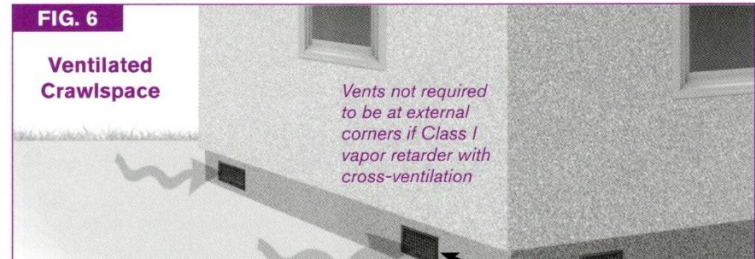

GARAGES & CARPORTS

- General** (see p. 13 for garage doors) **21 IRC**
- Floor surfaces approved noncombustible material EXC _____ 309.1&2
 - Asphalt OK at ground level in carports _____ 309.2X
 - Vehicle space floors sloped to a drain or to main vehicle entry door _ 309.1&2
 - Carports not open on 2 sides considered a garage _____ 309.2
- Common Walls, Ceilings & Penetrations**
- Min 1/2-in. GB on garage side fastened per **T9** _____ T302.6
 - 5/8-in. GB on garage ceiling under habitable rooms fastened per **T9** _ T302.6
 - Min 1/2-in. GB on walls supporting ceiling that provides separation ___ T302.6
 - Ducts from house to garage min 26-gauge steel & no garage openings 302.5.2
 - Seal (fireblock) penetrations of garage/house separation _____ 302.5.3
 - No openings between garage & sleeping rooms _____ 302.5.1
 - Doors between house & garage min 1 3/8-in. solid wood or steel (solid or honeycomb core) or 20-minute rated _____ 302.5.1
 - Door to living area self-closing or automatic-closing & self-latching **302.5.1¹⁹**

FIREPLACES & CHIMNEYS

- Masonry Fireplaces** **21 IRC**
- Footing min 12 in. thick & 6 in. beyond all sides _____ 1003.2
 - Hearth (in firebox) min 4 in. thick, hearth extension min 2 in. thick 1001.9.1&2
 - Hearth extension min 16 in. deep & 8 in. to sides if opening <6 sq. ft. 1001.10
 - Extension min 20 in. deep & 12 in. to sides if opening ≥6 sq. ft. ___ 1001.10
 - Framing min 2 in. from sides & 4 in from back EXC _____ 1001.11
 - Exterior wood OK if 12 in. from inside surface of firebox lining ___ 1001.11X3
 - Direct contact OK on fireplace front if >6 in. from opening _____ 1001.11X4
 - Combustible material within 12 in. of opening limited to max 1/8-in. projection for each inch of clearance from opening _____ 1001.11X4
 - Damper min 8 in. above top of fireplace opening _____ 1001.7.1
- Masonry Chimneys**
- Reinforcement & anchoring in SDC D _____ 1003.3&4
 - Clearance to combustible framing min 2 in. EXC _____ 1003.18
 - Exterior wood OK if 8 in. from interior of flue liner _____ 1003.18X3
 - Noncombustible fireblocking between framing & chimney _____ 1003.19
 - Termination min 3 ft. above roof & 2 ft. above building within 10 ft. ___ 1003.9
 - Chimney cap w/ drip edge & caulked bond break at flue liner _____ 1003.9.1
 - Spark arresters min net free area min 4× area of flue opening _____ 1003.9.2
- Manufactured Fireplaces & Chimneys**
- Must be L&L per UL 127 & installed AMI _____ 1004.1
 - Hearth extension per listing & distinguishable from surrounding floor _ 1004.2
 - Decorative shrouds L&L for specific fireplace system & installed AMI _ 1004.3
 - Replacement parts per MFR only (refractory panels, caps, doors, etc.) 1004.1
 - Inserts only OK if tested per UL 127 for specific installed fireplace ___ 1004.1
 - Insulation shield w/ clearance AMI & min 2 in. above insulation _____ 1005.8

HABITABILITY

- Minimum Light & Ventilation** **21 IRC**
- Habitable room glazed openings (skylights, windows) min 8% of floor area; natural ventilation openings min 4% of floor area EXC _____ 303.1
 - Where escape & rescue not required & w/ mechanical ventilation _ 303.1X1
 - Kitchens w/ local exhaust do not require windows to be openable **303.1X2²⁰**
 - Bathroom windows min 3 sq. ft., half of window openable EXC _____ 303.3
 - Not required if artificial light & local exhaust provided _____ 303.3X
 - Bathroom exhaust rate 50 cfm intermittent or 20 cfm continuous _ T1505.4.4
 - Bath exhaust direct to outdoors—not into attic, crawl, etc. _ 303.3X & 1501.1
 - 2 rooms considered 1 for light & ventilation if opening min 50% of common wall & opening min 10% of floor area & min 25 sq. ft. _____ 303.2
 - Whole-house ventilation system required when built to energy code ___ 303.4
- Room Dimensions**
- Hallways min 36 in. wide _____ 311.6
 - Habitable rooms except kitchens min 70 sq. ft. & least dimension 7 ft. 304.1&2
 - Ceilings in habitable rooms & hallways min 7 ft. EXC _____ 305.1
 - Sloped ceiling rooms min 50% of required floor area min 7 ft. ___ 305.1X1
 - Areas w/ sloped ceilings <5 ft. do not count as part of required area 305.1X1
 - Beams may project to within 6 ft. 6 in. AFF if spaced 3 ft. O.C. _ **305.1X4²¹**
 - Bathrooms, toilet rooms & laundry rooms min 6 ft. 8 in. _____ 305.1
 - Basement areas w/o habitable space min 6 ft. 8 in. ceiling EXC ___ 305.1.1
 - Beams & ducts may project to within 6 ft. 4 in. of basement floor _ 305.1.1X

INTERIOR WALL COVERS

- Gypsum Board** **21 IRC**
- Protect from adverse weather during construction _____ 701.2
 - Install only after rough inspections & insulation completed _____ 109.1.2
 - Fastening per **T9** _____ 702.3.5

TABLE 9 GYPSUM BOARD FASTENER SCHEDULE^A ◆ T702.3.5

Location	Orientation to framing	Max. frame spacing	Nails	Screws
Ceilings ^B	Perpendicular	24 in.	7	12
Ceilings ^B	Either	16 in.	7	12
Walls	Either	24 in.	8	12
Walls	Either	16 in.	8	16

A. For either 1/2-in. or 5/8-in. Type X gypsum board
 B. Gypsum board on garage ceiling beneath habitable space must be perpendicular to framing & fastened max 6 in. O.C. w/ 1 7/8-in. 6d nails or equivalent screws penetrating min 5/8 in. into wood.

- Wet Interior Areas** **21 IRC**
- Fiber-cement, fiber-mat reinforced cement, glass-mat gypsum & fiber-reinforced gypsum backers OK in tub/shower areas AMI _____ 702.4.2
 - Water-resistant GB (purple board) not allowed where subject to direct water exposure (tubs/showers) or high humidity (saunas) ___ 702.3.7.1
 - Water-resistant GB OK on ceilings, seal cut edges per MFR _____ 702.3.7
 - Water-resistant GB OK as mud-tile shower backer _____ 702.3.7

WALL FRAMING

Stud Framing

21 IRC

- Studs full bearing on min 2-in. plate at least equal to stud width _____ 602.3.4
- 3 studs min at corners EXC _____ F602.3(2)
 - 2 studs OK w/ cleats for attaching interior surfaces _____ F602.3(2)
- Notching 25% max in bearing wall, 40% non bearing **F11** _____ 602.6#1
- Bored holes 40% max in bearing, 60% non bearing **F11** EXC _____ 602.6#2
 - Notching/boring exceeding above OK w/ approved stud shoes AMI 602.6X
- Holes min 5/8 in. from face of stud & not same area as notch **F11** _____ 602.6#2

Top Plates

- Overlap exterior top plates at corners & intersections of bearing walls _____ 602.3.2
- End joints must offset 24 in. min (see **T6** for nailing) _____ 602.3.2
- Joints need not be over studs _____ 602.3.2
- If notches/holes >50% plate width, min 16-gauge 1 1/2-in. strap w/ min 8 10d nails each side of notch/hole **F10** EXC _____ 602.6.1
 - Not when WSP sheathing covers notch _____ 602.6.1X

FIG. 10

Top Plate Notches

16d common @ 16 in. O.C. or 10d box @ 12 in. O.C.



If top plate has notches or holes >50% of width of plate, install galvanized 16-gauge metal tie w/ 8 10d nails each side of notch or structural panel sheathing on entire side of notched wall.

Wood Structural Panel Sheathing

21 IRC

- Panels require grade stamp from approved agency _____ 602.1.8
- Fasten direct to framing members _____ 602.3
- Fasteners into PT wood AMI (min G185 zinc or equivalent) _____ 317.3.1

Bracing

- All buildings require prescriptive bracing or engineered design _____ 602.10
- BWL is straight line in plan view _____ 602.10.1
- BWP may offset 4 ft. from BWL, max 2/3 on one side of BWL _____ 602.10.1.5
- Can be intermittent, continuous sheathing, or mixed methods _____ 602.10.4
- Let-in bracing not allowed in SDC D _____ T602.10.3(3)

FIG. 11

Notching & Boring Studs

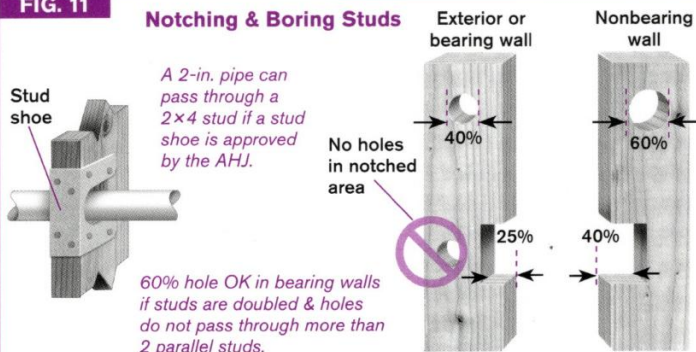

Headers

21 IRC

- Jack studs or approved framing anchors required end of header _____ 602.7.5
- Single member headers min. 2x material, face nail 12 in. O.C. top & bottom w/ 10d nails **F12** _____ 602.7.1
- Headers not required for nonbearing wall openings; single flat 2-in. x 4-in. member OK for span up to 8 ft. if ≤24 in. below nailing surface above 602.7.4

FIG. 12

Headers

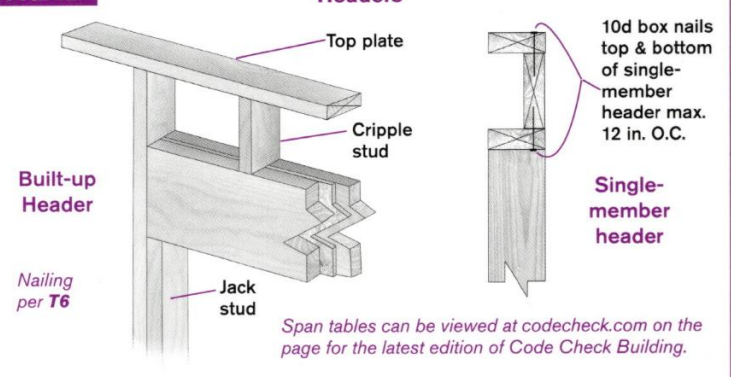

Cripple Walls

21 IRC

- Exterior cripple wall <14 in. continuously sheathed or solidly blocked_ 602.9⁶
- Studs ≥ studs above them; walls >4 ft. high sized as additional story_ 602.9

ROOF & CEILING FRAMING

Trusses

21 IRC

- Provide design drawings, calculations & approvals w/ delivery _____ 802.10.1
- No modifications or alterations w/o approval by design professional _____ 802.10.4
- Bracing AMI or SBCA guides (Structural Building Components Assoc.) _____ 802.10.3

Rafters & Ceiling Joists

- Span measured horizontally; rafters $\geq 3:12$ slope max spans **T4,5** 802.4.1&5.1
- Span can be measured from purlins that are no smaller than rafter _____ 802.4.5
- Purlin braces min 2×4 & max 45° from vertical, max length 8 ft. _____ 802.4.5
- Prefabricated wood I-joists AMI or per design (including boring) _____ 802.7.2
- Notching & boring same as floor joists & girders **F7** EXC _____ 802.7
 - Cantilevered eave rafters max 2 ft.; notch max $\frac{1}{4}$ depth **F13** _____ 802.7.1.1
 - Ceiling joist end cuts max $\frac{1}{4}$ joist depth at inside face **F14** _____ 802.7.1.2
- Ridge board min $1 \times$ & full depth of cut rafter _____ 802.3 & **802.4.27**
- Ridge straps or min 1×4 collar ties upper $\frac{1}{3}$ max 4 ft. O.C. _____ 802.4.6
- Ridge straps min 3 nails into each opposing rafter _____ **802.4.6^a**
- Opposing rafters max offset $1\frac{1}{2}$ in. _____ 802.4.2
- Hip & valley rafters min $2 \times$ & full depth of cut rafter _____ 802.4.3
- If roof pitch $< 3:12$, design ridges, hips & valleys as beams _____ 802.4.4
- If ceiling joists or rafter ties do not tie together opposing rafter ends, ridge must be designed as beam _____ 802.3
- Rafter ties min 2×4 , install in lower $\frac{1}{3}$ of every rafter pair _____ 802.5.2
- Headers & trimmers > 4 ft. doubled, hardware for headers > 6 ft. _____ 802.9
- Joist & rafter ends min $1\frac{1}{2}$ in. bearing on wood, 3 in. on masonry _____ 802.6
- Max deflection ceiling joists w/ flexible finish (GB) $L/240$ _____ 301.7
- Max deflection roof rafters $> 3:12$ slope $L/180$ ($\leq 3:12 - L/240$) _____ 301.7

TABLE 4

RAFTER HORIZONTAL SPANS^{A,B} ◆ T802.4.1(1)
10 LB. DEAD LOAD, 20 LB. LIVE LOAD, SLOPES $> 3:12$

Size	Douglas Fir-Larch #2 Spacing O.C.				Southern Pine #2 Spacing O.C.			
	12 in.	16 in.	19.2 in.	24 in.	12 in.	16 in.	19.2 in.	24 in.
2×4	10-10	9-10	9-1	8-2	10-4	9-0	8-2	7-4
2×6	16-10	14-7	13-3	11-11	15-7	13-6	12-3	11-0
2×8	21-4	18-5	16-10	15-1	19-8	17-1	15-7	13-11
2×10	26-0	22-6	20-7	18-5	23-5	20-3	18-6	16-6
2×12	> 26	26-0	23-10	21-4	> 26	23-10	21-9	19-6

A. Reduce span by $\frac{1}{3}$ if rafter ties at the max height of $\frac{1}{3}$ the distance between ceiling & ridge.
B. Ceiling not attached to rafters, deflection max $L/180$.

TABLE 5

CEILING JOIST SPANS: ATTICS WITHOUT STORAGE
10 LB. LIVE LOAD, 5 LB. DEAD LOAD ◆ T802.5(1)

Size	Douglas Fir-Larch #2 Spacing O.C.				Southern Pine #2 Spacing O.C.			
	12 in.	16 in.	19.2 in.	24 in.	12 in.	16 in.	19.2 in.	24 in.
2×4	12-5	11-3	10-7	9-10	11-10	10-9	10-2	9-3
2×6	19-6	17-8	16-8	15-0	18-8	16-11	15-7	13-11
2×8	25-8	23-4	21-4	19-1	24-7	21-7	19-8	17-7
2×10	> 26	> 26	26-0	23-3	> 26	25-7	23-5	20-11

FIG. 13

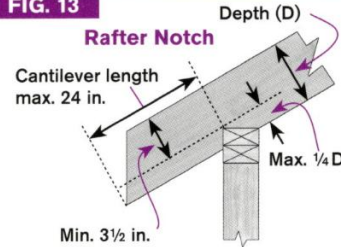
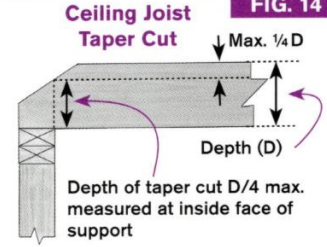

FIG. 14



ATTICS

General

21 IRC

- Access required if clear headroom height ≥ 30 in. for area ≥ 30 sq. ft. _____ 807.1
- Rough opening min 22 in. \times 30 in., headroom above hatch min 30 in. _____ 807.1
- Opening large enough to remove mechanical equipment **F52** _____ 1305.1.2

Vented Attics

- Cross ventilate each enclosed attic & rafter bay _____ 806.1
- Min net opening area $\frac{1}{150}^{\text{th}}$ of vented area EXC _____ 806.2
 - $\frac{1}{300}^{\text{th}}$ OK if 40%-50% in upper half & max 3 ft. below ridge (Climate zone 6, 7, or 8 also require Class I or II vapor retarder) _____ 806.2X
- Dimension of opening screenings min $\frac{1}{16}$ in. max $\frac{1}{4}$ in. _____ 806.1
- Clearance min 1 in. between insulation & sheathing near vents _____ 806.3

Unvented Attics

- Must be within BTE, no Class I vapor retarder (VR) on ceiling _____ 806.5
- Min $\frac{1}{4}$ -in. space between wood shingles & roof underlayment _____ 806.5
- CZ 5-8, air-impermeable insulation requires class II VR underneath _____ 806.5
- CZ 4-8, air-impermeable insulation above or below sheathing _____ T806.5
- CZ 1-3, vapor diffusion port ≤ 12 in. from top, 1:600 of ceiling area _____ 806.5

EXTERIOR WALL COVERINGS

General

21 IRC

- PT or NDW if <6 in. to ground or <2 in. to hardscape _____ 317.1#5
- Fasteners in PT min G185 HDG, SS, Cu or AMI, staples SS _____ 317.3.1
- Envelope must prevent water entry & allow moisture to drain to exterior 703.1.1
- WRB over studs or sheathing of all exterior walls _____ 703.2
- WRB = min #15 felt complying w/ ASTM D226 or other materials complying w/ ASTM E2556 or E331 _____ 703.2
- #15 felt layers lapped min 2 in. upper/lower, min 6 in. at vertical joints _ 703.2

Flashings

- Flashings to extend to exterior wall finish surface or to WRB _____ 703.4
- Flashing at window openings AMI; if no instructions provided, install pan, side, and head flashings _____ 703.4
- Flashings at chimneys, under & at ends of copings, continuously above projecting wood trim, roof/wall intersections & attachments, etc. 703.4

Stucco

- Install to ASTM C926 & C1063 (see *Code Check Building*) _____ 703.7
- 3-coat system required, except 2-coat OK over masonry **F15** _____ 703.7.2
- Weep screed min 4 in. to earth, 2 in. above hardscape **F15** _____ 703.7.2.1
- Min 2 layers Grade D paper or equivalent **F15** or 60-minute paper w/ nonabsorbent intervening drainage space _____ 703.7.3.1
- Flashing to drain between layers EXC _____ 703.7.3
- Where 60-minute Grade D paper used as above _____ 703.7.3X
- Lap paper/paper & wire/wire (not paper/wire/paper/wire) _____ 703.7.3
- Total thickness from sheathing min 7/8 in. _____ T702.1(1)

FIG. 15

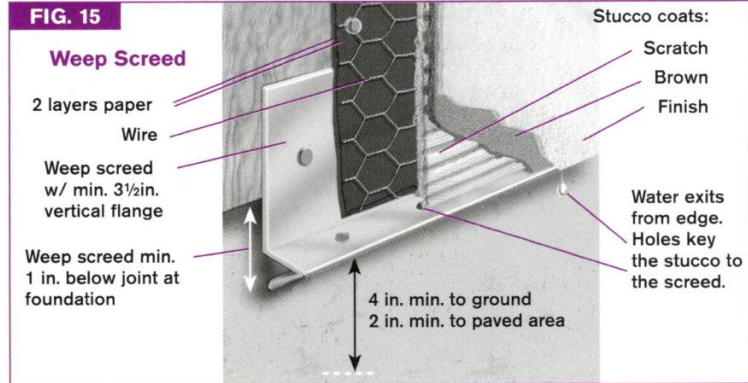

Masonry Veneer

21 IRC

- No additional loads (such as deck ledger) on masonry veneer _____ 703.8.3
- SDC A, B, C max thickness 5 in. (max 50 lb./sq. ft.) _____ T703.8(1)
- SDC D₀ & D₁ thickness ≤4 in., weight ≤40 psf; D₂: 3 in. & 30 psf _ T703.8(2)
- Max lintel span 18 ft. 3 in., min 18 in. of veneer each side _____ 703.8.3.2
- Min 4-in. length of bearing for lintels _____ 703.8.3
- Min 3/4-in. gap between top of veneer & structural frame _____ F703.8(2)
- Ties to studs or through max 2-in. insulating sheathing to WSP _____ 703.8.4⁹
- Metal ties max 32 in. O.C. horizontal & 24 in. O.C. vertical EXC **F16** 703.8.4.1
 - SDC D & townhouse SDC C each tie to support max 2 sq. ft. _ 703.8.4.1X
- Flashing to exterior beneath first course above ground level & at all other supports including lintels & row-lock courses **F16** _____ 703.8.5
- Min 3/16-in. weep holes directly above flashing, max 33 in. O.C. **F16** _ 703.8.6
- Min 1-in. air space between sheathing & veneer OR **F16** _____ T703.8.4(1)
 - Mortar/grout/foam fill over WRB _____ 703.8.4.2

FIG. 16

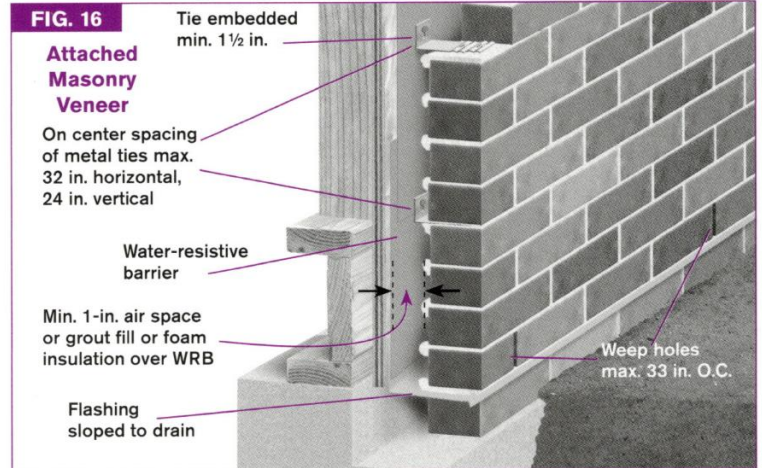

Vinyl Siding

21 IRC

- Install AMI & conform to ASTM D 3679 _____ 703.11
- Fasteners to penetrate into building framing min 1 1/4 in. _____ 703.11.1.2
- Vinyl over foam sheathing per wind load design pressure rating _____ 703.11.1.2

Exterior Insulation & Finish Systems (EIFS)

- Drainage-type systems required exc over concrete or masonry wall _____ 703.9.2
- Install AMI & in accordance w/ ASTM E 2568 _____ 703.9.1&2
- Terminate at least 6 in. above finished ground level _____ 703.9.1&2
- No decorative trim nailed through face of EIFS _____ 703.9.1&2

ROOF COVERINGS

General

21 IRC

- Ratings also apply to rooftop-mounted photovoltaic panels & modules_ 902.4
- Material packaging requires MFR identification & agency approvals ___ 904.4
- Install all roof materials AMI _____ 903.1
- Metal flashings min 26-gauge galv steel _____ 903.2.1
- Flashing at roof/wall intersections, penetrations & chimneys _____ 903.2
- Kickout flashings at intersection of sloped roof eave to wall **F17** _____ 903.2.1
- Drain discharge min 5 ft. from foundation if expansive or collapsible soil_ 801.3

Roof Sheathing

- WSP or solid lumber sheathing for asphalt shingle _____ 905.2.1
- WSPs require grade stamp & span rating _____ 803.2.1
- Nail WSPs 6 in. edge, 12 in. field (6 in. field if $\leq 3/4$ -in. WSP) ___ **T602.3(1)**^o
- WSP sheathing may cantilever up to 9 in. at gable w/o support ___ 803.2.3

Sloped Roofing

- In areas w/ history of ice forming at eaves, install ice-dam membrane from edge to at least 24 in. inside exterior wall line of building _____ 905.1.2
- Asphalt shingle min slope 2:12 _____ 905.2.2
- Asphalt shingle $\leq 4:12$ slope double underlayment shingle fashion_ 905.2.2
- Asphalt shingle min 4 nails min $3/4$ in. into (or through) sheathing ___ 905.2.5&6
- Asphalt shingle sidewall flashing behind siding and min 4 in. high ___ 905.2.8.3
- Drip edge & rake edge flashing required for asphalt shingles _____ 905.2.8.5
- Wood shingle/shake min 3:12 (see exposure tables) _____ 905.7.2 & 905.8.2
- SS fasteners for fire-retardant-treated wood roofing _____ 905.7.5 & 905.8.6
- Cricket required at chimneys & other penetrations >30 in. wide EXC_ 903.2.2
 - Unit skylights installed AMI _____ 903.2.2X

FIG. 17

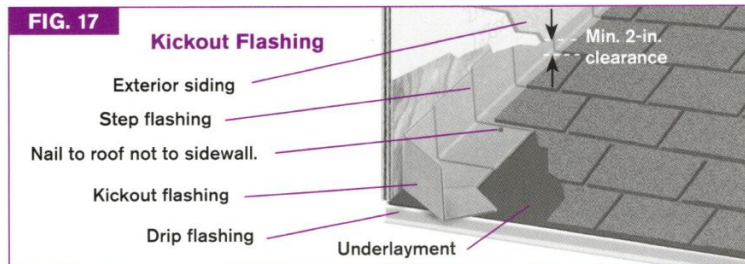

Low-Slope Roofing

21 IRC

- Membrane roofs min slope $1/4:12$ (2%) _____ 905.9.1 & 905.11-15.1
- Standing-seam metal min slope $1/4:12$ (2%) _____ 905.10.2#3
- Drains at each low point unless designed to drain over edge _____ 903.4
- Secondary drains 2 in. above low points, size same as main drain_ 903.4.1
- Scuppers 3x size of main & min opening height 4 in. _____ 903.4.1

TABLE 6

FASTENER SCHEDULE (PARTIAL) ♦ T602.3(1)

Connection	Fastener	Location
Joist to sill, top plate, or girder	4 8d box, 3 8d common, 3 10d box or 3 3-in. gun nails	toenail
Built-up girders & beams, 2-in. lumber layers	20d common or	32 in. O.C. top, bottom, staggered
	10d box or 3-in. gun nails and	24 in. O.C. staggered opposite sides
	2 20d or 3 10d box or 3-in. gun nails	Face nail at ends & each splice
Rim joist, band joist, or blocking to sill or top plate	8d box	4 in. O.C. toenail
	10d box or 3-in. gun nails	6 in. O.C. toenail
Band or rim joist to joist	3 16d common, 4 10d box, 4 3-in. gun nails or staples	end nail
Stud to stud @ intersections, corners & BWPs	16d box or 3-in. gun nails	12 in. O.C. face nail
	16d common	16 in. O.C. face nail
Adjacent full-height stud to end of header	4 10d box or 3-in. gun nail, or 16d box or 3 16d common	end nail
Built-up header, two 2x pieces w/ 1/2-in. spacer	16d common	16 in. O.C. each edge face nail
	16d box	12 in. O.C. each edge face nail
Top plate to top plate	16d common	16 in. O.C. face nail
	10d box or 3-in. gun nail	12 in. O.C. face nail
Double top plate splice lap area	12 10d or 16d box, 12 3-in. gun nails, 8 16d common	face nail each side of end joint (min 24 in. lap splice length each side)
Bottom plate to joist, rim joist, band joist, or blocking (not at BWPs)	16d common	16 in. O.C. face nail
	16d box or 3-in. gun nails	12 in. O.C. face nail
Bottom plate to joist, rim joist, band joist, or blocking (at BWPs)	2 16d common or 3 16d box or 4 3-in. gun nails	16 in. O.C. face nail
Top or bottom plate to stud	4 8d common or box, 10d box, or 3-in. gun nails or 3 16d box	toenail
	3 10d or 16d box or 3-in. gun nails or 2 16d common	end nail
Top plate corners & intersections	2 16d common or 3 10d box or 3-in. gun nails	face nail
Ceiling joists to plate	3 10d box, 8d common, or 3-in. gun nails or 4 8d box	toenail each joist
Ceiling joists to parallel rafters (heel joints) or rafter ties to rafters	depends upon rafter slope	face nail—see IRC T802.5.2(1)
Ceiling joists, laps over partitions (joists not functioning as rafter tie)	4 10d box or 3-in. gun nails, or 3 16d common	face nail
Collar tie to rafter	4 10d box or 3-in. gun nail, or 3 10d common	face nail (or $1\frac{1}{4} \times 20$ -gauge ridge strap to rafter)
Rafter or roof truss to plate	4 10d box or 3-in. gun nail, 3 10d common or 16d box	2 toenails on one side & 1 toenail on opposite side
	4 10d box, 3-in. gun nail or 16d box, or 3 10d common	toenail
Rafter to min. 2-in. ridge, valley, or hip rafters	2 16d common or 3 16d or 10d box or 3-in. gun nail	end nail

EGRESS

Required Egress Doors

21 IRC

- Min 1 w/ direct exterior access to public way (not through garage) 311.1&2
- Door side-hinged & net 32 in. from face of door to stop @ 90° open 311.2
- No key or special effort allowed to operate door from inside 311.2

Landings at Doors

- Landing length min 36 in. each side all exterior doors EXC 311.3
 - <36 in. OK for exterior balconies <60 sq. ft. & only accessed by door 311.3X
- Threshold max 1½ in. above floor or landing EXC 311.3.1
 - Required egress door(s): 7¾ in. below threshold OK for exterior landing if door does not swing over landing 311.3.1X
 - Other exterior doors: Stairs w/ 1 or 2 risers do not require upper landing on exterior side of door if door does not swing over stairway 311.3.2X
- Screen doors OK to swing over exterior stairs and landings 311.3.3

Decks & Balconies

- Decks to be designed for greater of live load or snow load 507.1¹¹
- All wood min #2 grade PT or NDW 317.1#8 & 507.2.1¹²
- Landings, decks, balconies & stairs require positive anchor (no toenails) 311.5
- Deck self-supporting if integrity of ledger connection not verifiable 507.8
- Cuts, holes & notches in PT wood require field treatment 507.2.1
- Beam splices must bear on supports 507.5.1
- Fasteners hot-dipped galv or SS; connectors min G185 or SS 507.2.3
- Ledger to band joist min ½-in. bolts or approved structural screws AMI 507.9.1.3
- Ledgers cannot be supported on stone or masonry veneer 507.9.1.1
- Lateral loads must transfer to earth or structure transmitting to earth 507.9.2
- Install composite materials AMI 507.2.2.5

Stairs and Stairways

21 IRC

- Stair = change of elevation of one or more risers 202
- Stairway = one or more flights of stairs + their landings 202
- Provide egress by stairway or ramp from all habitable levels 311.4
- Stairways that do not serve a building, porch, or deck & stairways to crawlspaces or nonhabitable attics not regulated by these provisions 311.7X¹³
- Floor or landing required top & bottom of stairs EXC 311.7.6
 - Door may not swing over stairs 311.7.6X
- Stairway headroom above nosings **F20** min 6 ft. 8 in. 311.7.2
- Min stairway width (measured above handrail) 36 in. 311.7.1
- Handrails may project into required width max 4½ in. EXC **F19** 311.7.8.2
 - 6½ in. OK at passing tread projection if min width maintained 311.7.8.2X
- Min width at & below handrails 31½ in. if 1 handrail, 27 in. if 2 311.7.1
- Max riser height 7¾ in., min tread depth 10 in. **F18** 311.7.5.1&2
- Measure rise & run exclusive of carpets, rugs, or runners 311.7.5
- Max ⅜-in. variance between tallest/shortest riser within flight **F18** 311.7.5.1
- Max ⅜-in. variance between deepest/shortest tread within flight **F18** 311.7.5.2
- If tread depth <11 in., nosing min ¾ in. max 1¼ in. & uniform **F18** 311.7.5.3
- Open risers >30 in. above floor or grade openings must be <4 in. 311.7.5.1
- Max vertical rise 151 in. between landings or floor levels 311.7.3¹⁴

Winder Treads

- Tread depth measured at walkline 12 in. from inside turn of stairway 311.7.4
- Tread depth min 6 in. @ at inside turn, min 10 in. @ walkline 311.7.5.2.1
- Dimensional uniformity required at walkline EXC 311.7.5.2.1
 - Depth of rectangular treads in same flight not required to be the same as the winder treads 311.7.5.2.1

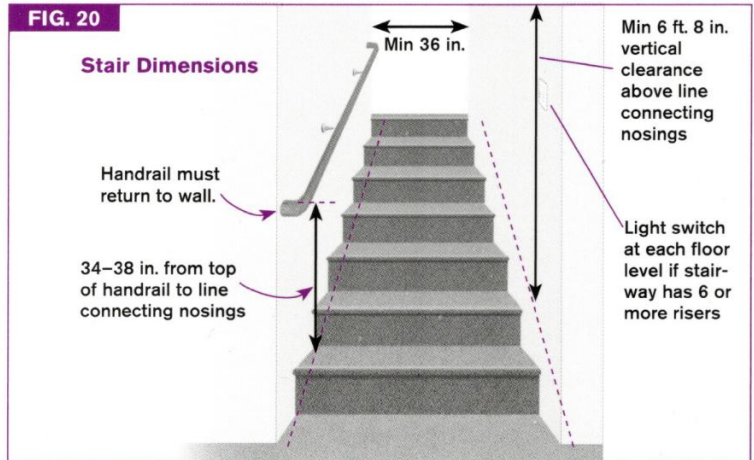
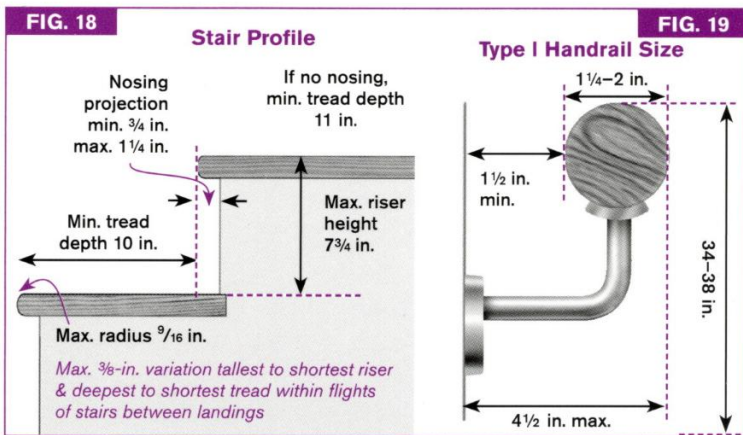

Required Lighting Locations

21 IRC

- Interior stairways require illumination for entire stairway _____ 303.7&8
- Switch required at each floor level of interior stairway if ≥ 6 risers _____ 303.7
- Exterior stairways: Light source at top landing or at bottom if to basement 303.8

Handrails

- Required min one side of each flight w/ 4 or more risers **F20** _____ 311.7.8
- Must resist 200-lb. concentrated load in any direction _____ T301.5
- Height to top of handrail min 34 in., max. 38 in. **F19-21** _____ 311.7.8.1
- Circular handrail diameter min 1 1/4 in. max 2 in. **F19** _____ 311.7.8.5#1
- Non-circular handrail perimeter 4-6 1/4 in., max cross section 2 1/4 in. 311.7.8.5#1
- If perimeter $> 6 1/4$ in., graspable finger recess both sides of rail _____ 311.7.8.5#2
- Min 1 1/2-in. space to wall **F19** _____ 311.7.8.3
- End handrail at wall return, post, or volute **F20,21** _____ 311.7.8.4

FIG. 21

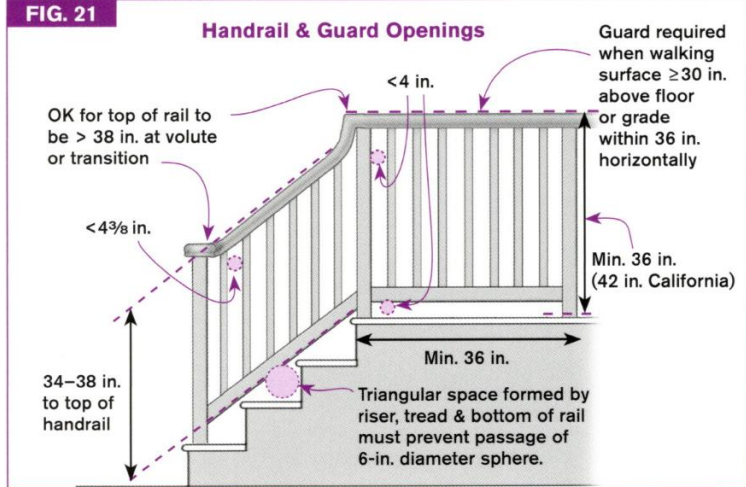

Guards F21

21 IRC

- Required for portions of open-sided walking surface more than 30 in. above floor or grade within 3 ft. horizontally of open side _____ 312.1.1
- Min height 36 in. (min 34 in. if guard is also stair handrail) _____ 312.1.2
- Openings not to allow passage of 4-in. sphere EXC (see **F21**) _____ 312.1.3
- Must resist 200-lb. point load downward or away from walking surface T301.5¹⁵

Window Fall Protection

21 IRC

- Operable windows w/ sill > 72 in. above exterior surface below & sill < 24 in. AFF require fall protection: _____ 312.2.1
 - Openings < 4 in. at max open position _____ 312.2.1#1
 - Fall prevention devices that comply w/ ASTM F 2090 _____ 312.2.1#2
 - Opening control devices that comply w/ ASTM F 2090 _____ 312.2.1#2
- Control devices in released position cannot reduce clear opening area of escape & rescue windows to less than amount required in **T7,8** _____ 312.2.2

Emergency Escape & Rescue Openings

- Required for basements, habitable attics & sleeping rooms EXC **F22** _____ 310.1
 - Storm cellars & mechanical equipment basements ≤ 200 sq. ft. _____ 310.1X1
 - In sprinklered dwellings w/ basement sleeping rooms: either 1 opening + a means of egress, or 2 means of egress paths (stairs, egress door) 310.1X2
- Bottom of clear opening max 44 in. AFF **F22** _____ 310.2.3¹⁶
- Net clear opening ≥ 5.7 sq. ft. & min 20 in. wide & 24 in. high EXC **T7** 310.2.1
 - Grade-floor openings & below-grade openings 5.0 sq. ft. OK **T8** _____ 310.2.1X
 - Existing windows 4 sq. ft. OK for change of use of existing space _____ 310.6X3¹⁷
- Area/window well required if bottom of clear opening below grade _____ 310.2.2
- Area/window wells min 9 sq. ft. & 36 in. min horizontal dimension **F22** 310.2.3
- Permanent ladder required if > 44 in. vertical depth **F22** _____ 310.2.3.1
- Area well steps min. tread depth 5 in., max. riser height 18 in. _____ 310.4.2.2¹⁸
- Security bars & area well covers must be releasable from inside w/o key or tool & be no heavier than window operation _____ 310.4

FIG. 22

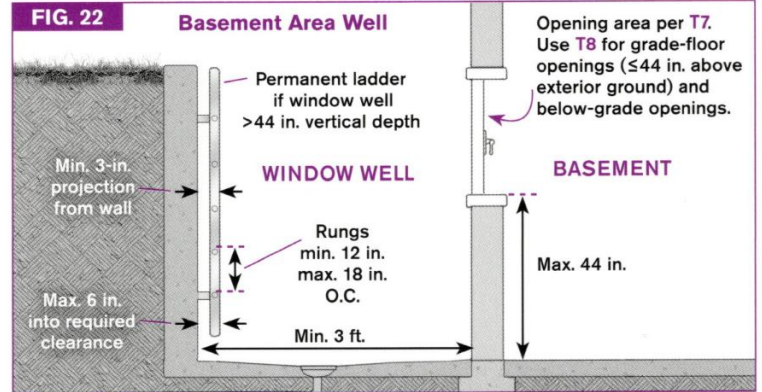

TABLE 7

WINDOW ESCAPE & RESCUE: MIN. HEIGHT & WIDTH FOR 5.7 SQ. FT. OPENING SIZE (IN.)

Width	20	20 1/2	21	21 1/2	22	22 1/2	23	23 1/2	24	24 1/2	25	25 1/2	26	26 1/2	27	27 1/2	28	28 1/2	29	29 1/2	30	30 1/2	31	31 1/2	32	32 1/2	33	33 1/2	34 1/2
Height	41	40	39 1/2	38 1/2	37 1/2	36 1/2	35 1/2	35	34 1/2	33 1/2	33	32 1/2	32	31	30 1/2	30	29 1/2	29	28 1/2	28	27 1/2	27	26 1/2	26 1/2	26	25 1/2	25	24 1/2	24

TABLE 8

WINDOW ESCAPE & RESCUE FOR 5.0 SQ. FT. OPENING: GRADE-FLOOR OR BELOW-GRADE OPENINGS ONLY (IN.)

Width	20	20 1/2	21	21 1/2	22	22 1/2	23	23 1/2	24	24 1/2	25	25 1/2	26	26 1/2	27	27 1/2	28	28 1/2	29	29 1/2	30
Height	36	35 1/2	34 1/2	33 1/2	33	32	31 1/2	31	30	29 1/2	29	28 1/2	28	27 1/2	27	26 1/2	26	25 1/2	25	24 1/2	24

GARAGES & CARPORTS

- General** (see p. 13 for garage doors) **21 IRC**
- Floor surfaces approved noncombustible material EXC _____ 309.1&2
 - Asphalt OK at ground level in carports _____ 309.2X
 - Vehicle space floors sloped to a drain or to main vehicle entry door _ 309.1&2
 - Carports not open on 2 sides considered a garage _____ 309.2
- Common Walls, Ceilings & Penetrations**
- Min 1/2-in. GB on garage side fastened per **T9** _____ T302.6
 - 5/8-in. GB on garage ceiling under habitable rooms fastened per **T9** _ T302.6
 - Min 1/2-in. GB on walls supporting ceiling that provides separation _ T302.6
 - Ducts from house to garage min 26-gauge steel & no garage openings 302.5.2
 - Seal (fireblock) penetrations of garage/house separation _____ 302.5.3
 - No openings between garage & sleeping rooms _____ 302.5.1
 - Doors between house & garage min 1 3/8-in. solid wood or steel (solid or honeycomb core) or 20-minute rated _____ 302.5.1
 - Door to living area self-closing or automatic-closing & self-latching **302.5.1¹⁹**

FIREPLACES & CHIMNEYS

- Masonry Fireplaces** **21 IRC**
- Footing min 12 in. thick & 6 in. beyond all sides _____ 1003.2
 - Hearth (in firebox) min 4 in. thick, hearth extension min 2 in. thick 1001.9.1&2
 - Hearth extension min 16 in. deep & 8 in. to sides if opening <6 sq. ft. 1001.10
 - Extension min 20 in. deep & 12 in. to sides if opening ≥6 sq. ft. ____ 1001.10
 - Framing min 2 in. from sides & 4 in from back EXC _____ 1001.11
 - Exterior wood OK if 12 in. from inside surface of firebox lining _ 1001.11X3
 - Direct contact OK on fireplace front if >6 in. from opening _____ 1001.11X4
 - Combustible material within 12 in. of opening limited to max 1/8-in. projection for each inch of clearance from opening _____ 1001.11X4
 - Damper min 8 in. above top of fireplace opening _____ 1001.7.1
- Masonry Chimneys**
- Reinforcement & anchoring in SDC D _____ 1003.3&4
 - Clearance to combustible framing min 2 in. EXC _____ 1003.18
 - Exterior wood OK if 8 in. from interior of flue liner _____ 1003.18X3
 - Noncombustible fireblocking between framing & chimney _____ 1003.19
 - Termination min 3 ft. above roof & 2 ft. above building within 10 ft. ____ 1003.9
 - Chimney cap w/ drip edge & caulked bond break at flue liner _____ 1003.9.1
 - Spark arresters min net free area min 4× area of flue opening _____ 1003.9.2
- Manufactured Fireplaces & Chimneys**
- Must be L&L per UL 127 & installed AMI _____ 1004.1
 - Hearth extension per listing & distinguishable from surrounding floor _ 1004.2
 - Decorative shrouds L&L for specific fireplace system & installed AMI _ 1004.3
 - Replacement parts per MFR only (refractory panels, caps, doors, etc.) 1004.1
 - Inserts only OK if tested per UL 127 for specific installed fireplace ____ 1004.1
 - Insulation shield w/ clearance AMI & min 2 in. above insulation _____ 1005.8

HABITABILITY

- Minimum Light & Ventilation** **21 IRC**
- Habitable room glazed openings (skylights, windows) min 8% of floor area; natural ventilation openings min 4% of floor area EXC _____ 303.1
 - Where escape & rescue not required & w/ mechanical ventilation _ 303.1X1
 - Kitchens w/ local exhaust do not require windows to be openable **303.1X2²⁰**
 - Bathroom windows min 3 sq. ft., half of window openable EXC _____ 303.3
 - Not required if artificial light & local exhaust provided _____ 303.3X
 - Bathroom exhaust rate 50 cfm intermittent or 20 cfm continuous _ T1505.4.4
 - Bath exhaust direct to outdoors—not into attic, crawl, etc. _ 303.3X & 1501.1
 - 2 rooms considered 1 for light & ventilation if opening min 50% of common wall & opening min 10% of floor area & min 25 sq. ft. _____ 303.2
 - Whole-house ventilation system required when built to energy code ____ 303.4
- Room Dimensions**
- Hallways min 36 in. wide _____ 311.6
 - Habitable rooms except kitchens min 70 sq. ft. & least dimension 7 ft. 304.1&2
 - Ceilings in habitable rooms & hallways min 7 ft. EXC _____ 305.1
 - Sloped ceiling rooms min 50% of required floor area min 7 ft. ____ 305.1X1
 - Areas w/ sloped ceilings <5 ft. do not count as part of required area 305.1X1
 - Beams may project to within 6 ft. 6 in. AFF if spaced 3 ft. O.C. _ **305.1X4²¹**
 - Bathrooms, toilet rooms & laundry rooms min 6 ft. 8 in. _____ 305.1
 - Basement areas w/o habitable space min 6 ft. 8 in. ceiling EXC ____ 305.1.1
 - Beams & ducts may project to within 6 ft. 4 in. of basement floor _ 305.1.1X

INTERIOR WALL COVERS

- Gypsum Board** **21 IRC**
- Protect from adverse weather during construction _____ 701.2
 - Install only after rough inspections & insulation completed _____ 109.1.2
 - Fastening per **T9** _____ 702.3.5

TABLE 9 GYPSUM BOARD FASTENER SCHEDULE^A ◆ T702.3.5

Location	Orientation to framing	Max. frame spacing	Nails	Screws
Ceilings ^B	Perpendicular	24 in.	7	12
Ceilings ^B	Either	16 in.	7	12
Walls	Either	24 in.	8	12
Walls	Either	16 in.	8	16

A. For either 1/2-in. or 5/8-in. Type X gypsum board
 B. Gypsum board on garage ceiling beneath habitable space must be perpendicular to framing & fastened max 6 in. O.C. w/ 1 7/8-in. 6d nails or equivalent screws penetrating min 5/8 in. into wood.

- Wet Interior Areas** **21 IRC**
- Fiber-cement, fiber-mat reinforced cement, glass-mat gypsum & fiber-reinforced gypsum backers OK in tub/shower areas AMI _____ 702.4.2
 - Water-resistant GB (purple board) not allowed where subject to direct water exposure (tubs/showers) or high humidity (saunas) ____ 702.3.7.1
 - Water-resistant GB OK on ceilings, seal cut edges per MFR _____ 702.3.7
 - Water-resistant GB OK as mud-tile shower backer _____ 702.3.7

SAFETY GLAZING

Hazardous Locations Requiring Safety Glass F23

21 IRC

- Glazing in door assemblies EXC _____ 308.4.1
 - Decorative glazing & lites w/ smallest dimension <3 in. _____ 308.4.1X
- Glazing ≤24 in. of door when closed & w/ any part <60 in. AFF EXC _____ 308.4.2
 - Glazing not in same plane (<180°) as door & not on hinge side toward which the door swings _____ 308.4.2#2
 - Decorative glazing _____ 308.4.2X1
 - Where separated by wall or intervening barrier _____ 308.4.2X2
 - Where door only accesses closet <3 ft. deep _____ 308.4.2X3
 - Adjacent to fixed panel of patio doors _____ 308.4.2X4
- Windows meeting all of the following 4 conditions:
 - (1) bottom edge <18 in. above floor, (2) top edge >36 in. above floor,
 - (3) pane >9 sq. ft. & (4) ≤36 in. horiz from walking surface EXC _____ 308.4.3
 - Decorative glass _____ 308.4.3X1
 - Glass protected by horizontal rail on side w/ walking surface _____ 308.4.3X2
- All glazing in guards & railings _____ 308.4.4
- Glazing adjacent wet areas such as tubs, spas, showers & pools w/ lower edge of glass <60 in. above standing surface EXC _____ 308.4.5
 - Glazing >60 in. horizontally in a straight line from water's edge _____ 308.4.5X
- Glazing <3 ft. above walking surface of stair, landing, or ramp EXC _____ 308.4.6
 - Where protected by intervening rail 34–38 in. high & capable of withstanding 50 pounds per linear foot load w/o touching glass _____ 308.4.6X1
 - Where ≥36 in. horizontally from walking surface _____ 308.4.6X2
- Glazing ≤60 in. horizontally from bottom stair landing measured in <180° arc from lowest tread nosing & <36 in. above landing EXC _____ 308.4.7
 - Intervening guard min 18 in. horizontally from glass _____ 308.4.7X

Safety Glass Identification

- Permanent etched label (no paper labels) on tempered glass EXC _____ 308.1
 - Spandrel glass removable paper label OK _____ 308.1X2
- Only 1 lite requires etched label in multipane windows w/ lites ≤1 sq. ft., others marked "CPSC 16 CFR 1201" or "ANSI Z97.1" _____ 308.1.1
- Non-tempered glass (laminated) certificate OK in lieu of label _____ 308.1X1

WINDOWS, DOORS & GARAGE DOORS

Performance & Labeling

21 IRC

- Windows, sliding doors & exterior side-hinged doors require labeling from approved agency to indicate compliance w/ AAMA standards EXC _____ 609.3
 - Decorative glazed openings _____ 609.3X
- Written installation instructions required for each window & door _____ 609.1
- Anchor glass assemblies AMI to required design wind pressure _____ 609.7.1
- Impact performance testing requires permanent etched label _____ 609.6.2
- Garage door wind load tests per ASTM E330 ANSI/DASMA 108 _____ 609.4
- Garage door openers L&L per UL 325 (auto-reverse, photo-sensors <6 in. AFF, switch >60 in. AFF, release handle max 72 in. AFF) _____ 309.4
- Garage doors require permanent MFR label _____ 609.4.1²²
- Garage door opener battery backup in high fire hazard zones _____ local

FIG. 23

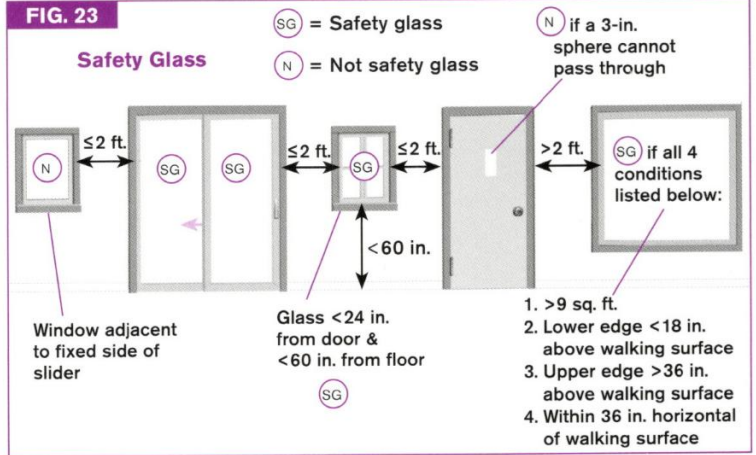

SKYLIGHTS

General

21 IRC

- Skylight = glazing at ≥15° from vertical _____ 308.6.1
- Unit skylight = factory-assembled glazed unit in roof assembly _____ 308.6.1
- Unit skylights & tubular daylighting devices require labeling from approved independent laboratory indicating performance grade rating & compliance w/ AAMA/WDMA/CSA 101/I.S.2/A440 _____ 308.6.9
- May be laminated, fully tempered, heat-strengthened, wired glass, or approved rigid plastics _____ 308.6.2
- Unit skylights min. 4-in. curb in roof w/ <3:12 slope unless AMI _____ 308.6.8
- Cricket or saddle if >30-in.-wide opening unless allowed AMI _____ 903.2.2

ENERGY EFFICIENCY

Intent & Scope

21 IRC

- Intended to ensure effective energy use & allow for innovation _____ 1101.2
- Software can be approved to demonstrate compliance _____ 1101.3
- Information to be included in construction documents: _____ 1101.5
 1. Energy compliance path
 2. Insulation materials & their R-values
 3. Fenestration U-factors & SHGC (solar heat gain coefficient)
 4. Area-weighted U-factor and SHGC calculations
 5. Mechanical system design criteria
 6. Mechanical & water heating equipment types, sizes & efficiencies
 7. Equipment & system controls
 8. Duct sealing, duct & pipe insulation & location
 9. Air sealing details

Certification

- Certificate of compliance with component performance values and test results posted at furnace, utility room, or other approved area _____ 1101.14
- Maintenance instructions required _____ 1101.12

FIRE PROTECTION

General

21 IRC

- Wall & ceiling surfaces of enclosed under-stair spaces that are accessed through doors or hatches min 1/2-in. GB _____ 302.7
- Walls/ceilings flame spread index ≤200, smoke developed index ≤450 302.9

Fireblocking: Purpose & Materials

- Resists free passage of flame through concealed spaces _____ 202
- Material may be 2× lumber, 1/2-in. GB, tightly packed & securely retained mineral wool or glass fiber batts & other approved materials _____ 302.11.1

Fireblocking: Required Locations

- Stud walls vertically @ floor & ceiling levels _____ 302.11#1
- Stud walls horizontally @ max 10-ft. intervals _____ 302.11#1
- Intersections such as soffits, drop & cove ceilings _____ 302.11#2
- Concealed space between stringers at top & bottom of stairs _____ 302.11#3
- Floor & ceiling openings for ducts, wires & pipes **F24** _____ 302.11#4
- Caulk at openings NOT required to be ASTM E 136 fire-rated **F24** 302.11#4
- Between chimneys & framing at floors & ceilings _____ 302.11#5

FIG. 24 Fireblocking of Openings at Ceilings and Floors

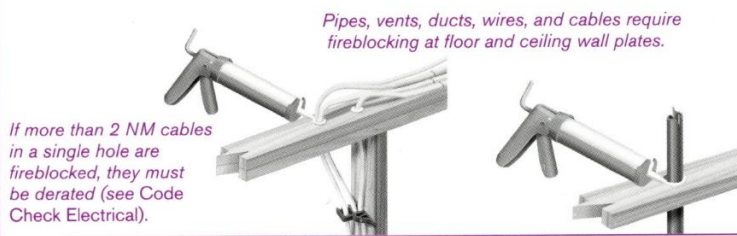

Draftstopping

21 IRC

- Floor/ceiling draftstopped if >1,000 sq. ft., divide areas equally (including open-web trusses or ceiling suspended from floor framing) 302.12
- Min 1/2-in. GB, 3/8-in. wood panels, or other approved materials _____ 302.12.1

SMOKE & CARBON MONOXIDE (CO) ALARMS

CO Alarms & Detectors F25

21 IRC

- Required in dwellings w/ fuel-fired systems or w/ attached garages _____ 315.2
- Install outside each separate sleeping area **A** _____ 315.3
- Install in bedroom or attached bath w/ fuel-burning device **B** _____ 315.3
- Alterations, repairs, additions compliance same as new EXC _____ 315.2.2
 - Work limited to exterior or to plumbing/mechanical alterations/repairs that are not fuel-fired appliances _____ 315.2.2X²³
- Primary power from building wiring plus battery backup EXC _____ 315.6
 - Battery power alone OK for alterations, repairs & additions _____ 315.6X2
- No disconnect switch on wiring other than branch circuit breaker _____ 315.6
- Combo smoke/CO alarms OK if L&L to UL 217 & UL 2034 315.1.1 & 315.4
- Interconnect so activation of one activates all alarms EXC _____ 315.5
 - Alterations where finishes not removed & no access to pull wire _____ 315.5X

Smoke Alarms & Detectors F25

21 IRC

- Alarms must comply w/ NFPA 72 (see below) & be listed to UL 217 _____ 314.1
- Install in each sleeping room & immediate vicinity outside bedrooms **C** 314.3
- Min 3 ft. from door to bath w/ tub or shower if no conflict w/ above **D** 314.3
- Min 1 on each story, including basements & habitable attics _____ 314.3
- Required for alterations, repairs & additions EXC _____ 314.2.2
 - Work on exterior including re-roofing, siding, window replacement or decks, or repairs/alterations to mechanical or plumbing systems 314.2.2X
- If open split level < 1 story below upper level, install on upper level _____ 314.3
- Photoelectric min 6 ft. to permanently installed cooking appliance **F** 314.3.1
- Ionization min 20 ft. from cooking, 10 ft. OK w/ hush button **F** _____ 314.3.1²⁴
- Primary power from building wiring plus battery backup EXC _____ 314.6
 - Battery power only OK for alterations, repairs & additions _____ 314.6X2
- No disconnect device on wiring other than branch circuit breaker _____ 314.6
- Interconnect so activation of one activates all alarms EXC _____ 314.4
 - Physical interconnection not needed for listed wireless alarms _____ 314.4
- Battery-only alarms must be 10 year & nonremovable battery _____ 314.1
- Fire alarm systems w/ UL 268 detectors OK in lieu of alarms _____ 314.7

FIG. 25 Smoke & CO Alarms

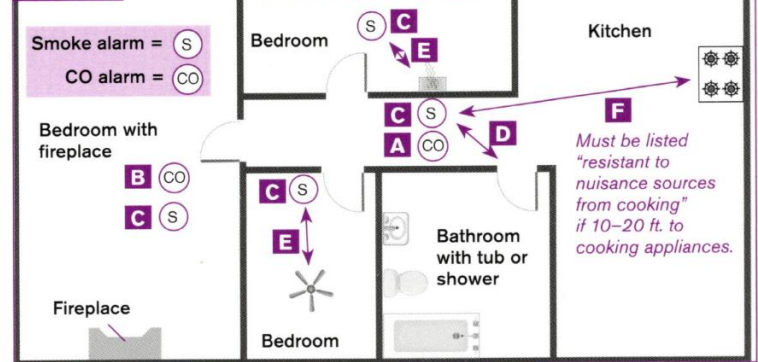

Additional Required Locations

NFPA 72

- Within 21-ft. path of travel outside of door to each sleeping area _____ 29.8.1.1(2)
- Min 3 ft. from forced-air outlet or tip of ceiling paddle fan blade **E** _____ 29.11.3.4
- If area outside sleeping area is separated from adjacent living areas by a door, alarm also required on living area side of door _____ 29.8.1.2
- Within 36 in. horizontal of high side of peaked ceiling or ceiling w/ rise greater than 1:8, min 4 in. from peak or adjoining wall _____ 29.11.3.1&2
- Wall-mounted detectors max. 12 in. below adjoining ceiling _____ 29.11.3.3
- Locate basement alarm on ceiling near entry to stairs _____ 29.11.3.4(10)
- For coffered ceilings, locate on highest portion or on sloped portion max. 12 in. vertically down from highest point _____ 29.11.3.4(11)
- Where interior floor area >1,000 sq. ft. for given level, max. travel distance to alarm from any point 30 ft., or min 1 alarm per 500 ft. _____ 29.8.1.3.1
- Where stairs lead to occupiable levels, locate such that smoke rising in stairway not prevented by a door from reaching the alarm _____ 29.11.3.4(9)
- Not in spaces where temperatures can be <40°F or >100°F _____ 29.11.3.4(2)

PIPING INSTALLATION & PROTECTION

General	21 IRC	21 UPC
<input type="checkbox"/> Max support intervals T10 _____ 2605.1#5	313.3	
<input type="checkbox"/> Support to resist sagging & distortion or upward thrust _ 2605.1	313.2&4	
<input type="checkbox"/> Use approved hangers AMI _____ 2609.2	313.1&2	
<input type="checkbox"/> Min 16-gauge steel shield if < 1/4 in. from edge of framing F29 (IRC: 2 in. above sole plate & 2 in. below top plate) ___2603.2.1	n/a	
(UPC: 18-gauge, ≤ 1 in. & 1/2 in. past hole) _____	312.9	
<input type="checkbox"/> Where regionally necessary, protect from freezing outside BTE (crawlspaces, attics, outdoors, etc.) _____ 2603.5	312.6	
<input type="checkbox"/> Pipes & fittings must bear MFR identification & markings required by applicable standards, except field-cut pipe nipples ___ 2609.1	301.2.1	

Trenching & Backfilling

<input type="checkbox"/> Sewer depth per local AHJ & utility _____ 2603.5.1	718.3	
<input type="checkbox"/> Water service min 12 in. cover below final grade _____ 2603.5	609.1	
<input type="checkbox"/> Water service min 6 in. (UPC: 12 in.) below frost line ___ 2603.5	609.1	
<input type="checkbox"/> Plastic underground water service requires #14 blue-insulated tracer wire terminating above ground at each end _____ n/a	604.10.1	
<input type="checkbox"/> Water pipe & sewer OK in same trench unless sewer material is clay or other material not approved inside house F26 ___ 2906.4.1	609.2	
<input type="checkbox"/> Backfill layered & tamped in place—no backhoe or grader until 12 in. of tamped earth above pipe F28 _____ 2604.3	314.4	
<input type="checkbox"/> (UPC) Trench width for plastic pipe min 16 in. + pipe o.d. or 12 in. + 1/4× pipe o.d. or per MFR (ASTM D2321) F28 ___ n/a	314.4.1	
<input type="checkbox"/> Utility or other trench may not undermine footing F27 ___ 2604.4	314.1	
<input type="checkbox"/> Pipes through foundation require sleeve or bored hole _ 2603.4	312.10	

FIG. 26

Water & Sewer Separation

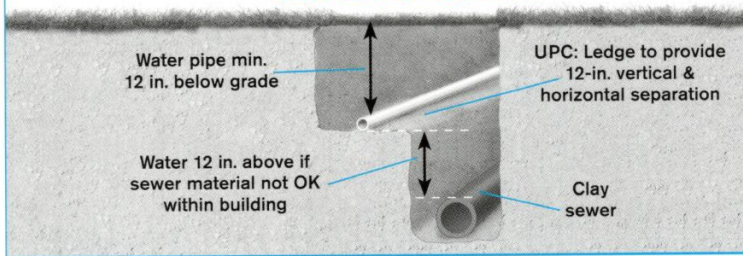
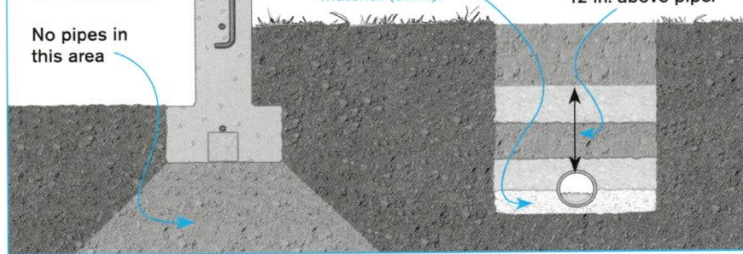

FIG. 27

Pipes Parallel to Footings



Trench Backfill

FIG. 28

FIG. 29

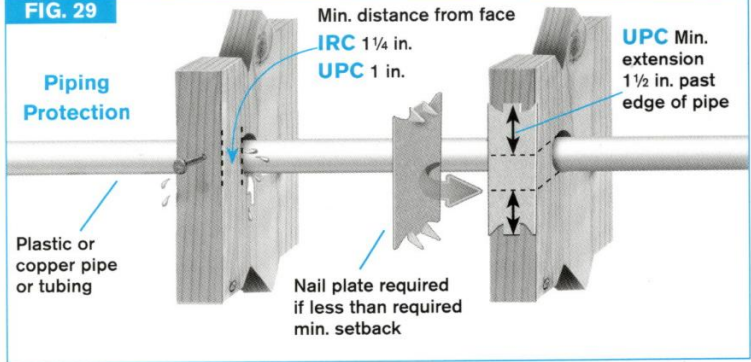

TABLE 10

MAX. SUPPORT INTERVALS ◆ IRC T2605.1 UPC T313.3

Pipe or Tube	Horizontal	Vertical
CPVC	3 ft. for ≤ 1 in. diameter, 4 ft. if ≥ 1 1/4 in.	IRC: 10 ft. & mid-story guides for ≤ 2 in. UPC: Base & each floor + mid-story guides
PEX	32 in. if ≤ 1 in. diameter, 4 ft. if ≥ 1 1/4 in.	
ABS & PVC ^A	4 ft.	IRC: 15 ft. UPC: Base & each floor & max. 15 ft.
Cast iron w/ no-hub fittings ^B	IRC: 5 ft. (10 ft. for 10-ft. pipes) UPC: Every joint if > 4 ft., ^C every other joint if ≤ 4 ft. ^C	
Cu Tubing	IRC: 6 ft. if ≤ 1 1/4 in., 10 ft. if ≥ 1 1/2 in. UPC: 6 ft. if ≤ 1 1/2 in., 10 ft. if ≥ 2 in.	

A. UPC: Provide for expansion every 30 ft.

B. UPC: Brace at max. 40-ft. intervals to prevent horizontal movement.

C. Support adjacent to joint within 18 in.; do not place hanger directly on coupling.

Piping under or Encased in Concrete Slabs 21 IRC 21 UPC

<input type="checkbox"/> Pipes through concrete wrapped or sheathed _____ 2603.3	312.2
<input type="checkbox"/> Cu water tubing underground beneath building min Type L _ n/a	604.3

Underground Gas Pipes

<input type="checkbox"/> Conduit or listed system if gas is below building _____ 2415.14	1210.1.6
<input type="checkbox"/> Min cover below grade 12 in. EXC _____ 2415.12	1210.1.1
• 18 in. if soil cultivation or heavy surface loads likely _____ n/a	1210.1.1
<input type="checkbox"/> Plastic OK only underground & outside building _____ 2415.17.1	1210.1.7
<input type="checkbox"/> Corrosion-resistant tracer wire min #18 (UPC #14) buried with plastic pipe & brought above ground at riser ___ 2415.17.3	1210.1.7.2
<input type="checkbox"/> Factory-applied & electrically insulated coating required for metal pipe; field wrapping OK AMI for threads & fittings _____ 2415.11.2(2) 1210.1.3(2)	

ROUGH INSPECTION: TESTING

Required Pre-Concealment Piping Tests 21 IRC 21 UPC

<input type="checkbox"/> Test all piping before cover or concealment _____ 2503.2	105.1
<input type="checkbox"/> DWV min 10-ft. head for 15 minutes OR _____ 2503.5.1 ²⁵	712.2
• Air test 5 psig (10 in. mercury) for 15 minutes _____ 2503.5.1	712.3
<input type="checkbox"/> Water pipe test 15 minutes w/ potable water at ≥ working pressure; non-plastic OK to test w/ air ≥ 50 psig air EXC _____ 2503.7	609.4
• Air OK for PEX if AMI for tubing & fittings _____ 2503.7X	609.4X
<input type="checkbox"/> Gas test min 10 min at 1 1/2× working pressure & min 3 psig (UPC: 15 min at 10 psig) _____ 2417.4.1&2	1213.3

DRAINAGE

General	21 IRC	21 UPC
<input type="checkbox"/> No roof/site drains to building drains unless OK by AHJ _ 3001.1		714.2
<input type="checkbox"/> Size traps, arms & drains according to DFU load T11,12 3005.4		703.1
<input type="checkbox"/> Thrust blocks for 4-in. drain >45° horizontal change _ 2605.1#4		n/a
<input type="checkbox"/> Allow for thermal expansion & contraction of ABS/PVC _ 2605.1		312.2
<input type="checkbox"/> ABS to PVC only at building drain to building sewer _ 3003.13.4		705.9.4
<input type="checkbox"/> No drilled or tapped connections (e.g., saddle fitting) _ 3003.2		310.2

TABLE 11	DFUS, TRAPS & TRAP ARM MAX LENGTHS IRC T3004.1, 3105.1 & 3201.7 UPC T702.1 & 1002.2			
	Fixture	Min. Trap Size	DFUs	IRC Trap Arm
Kitchen sink ^{A,B}	1 1/2 in.	2	6 ft.	3 ft. 6 in.
Laundry tub ^B	1 1/2 in.	2	6 ft.	3 ft. 6 in.
Clothes washer	2 in.	2 (UPC 3)	8 ft.	5 ft.
Floor drain	2 in.	0 (UPC 2)	8 ft.	5 ft.
Lavatory ^C	1 1/4 in.	1	5 ft.	2 ft. 6 in.
Bathtub	1 1/2 in.	2	6 ft.	3 ft. 6 in.
Shower ^{D,26}	2 in.	2	8 ft.	5 ft.
Water Closet	3 in.	3	no limit	6 ft.
Bidet	1 1/4 in.	1	5 ft.	2 ft. 6 in.









A. With or without dishwasher or disposer.
 B. UPC drain size after the trap arm is 2 in. - see T702.1.
 C. UPC drain size after the trap arm is 1 1/2 in. for sets of 2 or 3 lavatories - see T703.2.
 D. IRC shower traps can be 1 1/2 in. if aggregate flow rate is less than 5.7 gpm, UPC 1 1/2 in. can be on tub to shower retrofit.²⁶

TABLE 12	BRANCH DRAIN & VENT SIZE ◆ IRC T3005.4.1 UPC T703.2						
	Pipe size	1 1/4 in.	1 1/2 in.	2 in.	2 1/2 in.	3 in.	4 in.
IRC DFUs	Vertical	1	4	10	20	48	240
	Horizontal	1	3	6	12	20	160
	Wet Vents	∅	1	4	6	12	32
UPC DFUs	Vertical	1	2	16	n/a	48 ^A	256
	Horizontal	1	1	8	n/a	35 ^A	216 ^B
UPC Dry Vents ^C	Max DFUs	1	8	24	n/a	84	256
	Max Feet ^D	45	60	120	n/a	212	300

A. UPC: Horizontal drain pipe min. 4 in. if receiving >5 WCs.²⁷
 B. Based on 1/4 in./ft. slope. For 1/8 in./ft. slope, multiply by 0.8.
 C. IRC vents min 1 1/4 in. & min half the required drain diameter. IRC vents > 40 ft. increase 1 pipe size.
 D. UPC vents increase 1 pipe size if horizontal length > 1/3 the overall length.

Cleanouts	21 IRC	21 UPC
<input type="checkbox"/> Removable trap or WC OK except for building sewer 3005.2.10.1²⁸		∅
<input type="checkbox"/> Required at junction of building drain/building sewer or upstream if near junction (IRC: within 10 ft.) _____	3005.2.3	719.1
<input type="checkbox"/> Not required pipes ≤45° from vertical (UPC: 72°) _____	3005.2.1	707.4X2
<input type="checkbox"/> Not required above lowest floor level of the building _____	n/a	707.4X3
<input type="checkbox"/> C/O plugs brass or plastic, square head or countersunk _____	3005.2.6	707.1
<input type="checkbox"/> ≥18-in. horizontal clearance (UPC: 24-in. if pipe >2 in.) _____	3005.2.9	707.9
<input type="checkbox"/> Terminate C/Os above grade or under cover plate _____	3005.2.10	707.8
<input type="checkbox"/> Underfloor C/Os min 24-in. (UPC 18-in.) vertical access _____	3005.2.10	707.9
• Underfloor C/Os max 5 ft. from access opening _____	n/a	707.9

Slope, Fittings & Changes of Direction	21 IRC	21 UPC
<input type="checkbox"/> Min slope 1/4 in./ft., 1/8 in./ft. for ≥4 in. if OK by AHJ _____	n/a	708.1
<input type="checkbox"/> Min slope 1/4 in./ft., 1/8 in./ft. for ≥3 in. _____	3005.3 & T3105.1	n/a
<input type="checkbox"/> Use appropriate fittings for changes in direction T13 _____	3005.1	706.1
<input type="checkbox"/> No reductions in direction of flow EXC _____	3002.3.1	315.2
• 4×3-in. WC bend _____	3005.1.6	310.5
<input type="checkbox"/> Joints between different materials AMI _____	3003.13	705.1&2
<input type="checkbox"/> Cast-iron couplings require metallic shield & center stop _____	3003.4.3	705.2.2

TABLE 13 APPLICATION OF FITTINGS ◆ IRC T3005.1 & UPC 706				
Fitting	Horizontal to Vertical	Vertical to Horizontal	Horizontal to Horizontal	
1/16 bend 22.5° 	OK	OK	OK	
1/8 bend 45° 	OK	OK	OK	
1/4 bend 60° 	OK	OK	IRC: OK UPC: ∅	
1/2 bend 90° 	OK	IRC: A,B UPC: ∅ ^C	IRC: A UPC: ∅ ^C	
Long sweep 	OK	OK	OK	
Combo 	OK	OK	OK	
Wye 	OK	OK	OK	
Sanitary tee 	OK ^{D,E}	∅	∅	

A. Only allowed for 2-in. or smaller fixture drains.
 B. In cast iron only, a "short sweep" is allowed for Note A conditions and vertical-to-horizontal if ≥3 in.
 C. In cast iron only, the UPC allows "short sweep" fittings (radius > 1/4 bend and < long sweep).
 D. Double sanitary tees not to receive discharge from WCs unless min 18 in. between WC and fitting.
 E. Double sanitary tees in UPC must have barrel 2 pipe sizes larger than inlets.

Backwater Valves & Ejector Pumps	21 IRC	21 UPC
<input type="checkbox"/> Backwater valve for fixtures w/ FLR below next upstream manhole cover (UPC: on floor level below cover) _____	3008.1	710.1
<input type="checkbox"/> Fixtures above manhole not through backwater EXC _____	3008.1	710.1
• OK if backwater valve is normally open type _____	3008.2	n/a
<input type="checkbox"/> Backwater valve must remain accessible for service _____	3008.4	710.6
<input type="checkbox"/> Warning label for cleanouts leading to backwater valve _____	n/a	710.1
<input type="checkbox"/> Ejector required for fixtures below sewer crown level _____	3007.1	710.2
<input type="checkbox"/> Backwater or swing-check valve on ejector discharge pipe _____	3007.2	710.4
<input type="checkbox"/> Gate or ball valve on discharge side of check valve _____	3007.2	710.4
<input type="checkbox"/> Sump discharge must be lifted above gravity drain _____	3007.1	710.2
<input type="checkbox"/> Min 2-in. discharge piping _____	3007.6	710.3#2
<input type="checkbox"/> Connect to wye fitting at top of horizontal drain _____	3007.3.5	710.4

TRAPS & VENTS

Fixture Traps & Tailpieces

	21 IRC	21 UPC
Trap same size T11 as arm & not less than fixture tailpiece	3201.7	1003.3
Trap seal min 2 in., max 4 in. F30	3201.2	1005.1
Trap weir to vent min distance 2x trap arm diameter	3105.3	1002.2
Max total length of trap arm per T11,F30	3105.1	1002.2
Traps must be plumb	3201.3	1005.1
Max tailpiece length 24 in. vertical, 30 in. horizontal EXC	3201.6	n/a
• UPC tailpieces overall developed length max 24 in.	n/a	1001.2
Floor drains require trap primer (IRC: or barrier device)	3201.2.1	1007.1

Vents

Must be graded & supported to drain—no dips or sags	3104.2	905.1
Horizontal vent min 6 in. above fixture FLR	3104.5	905.3
Vent opening not below trap weir (toilet excepted) F30	3105.2	905.5
Dry vent connection to horizontal drain above centerline	3104.3	905.2
Min 1 vent ≥50% size of building sewer to open air	3114.7	n/a
Required sum of UPC vents ≥ size of building sewer	n/a	904.1

Air Admittance Valves (AAVs) **F36**

	21 IRC	21 UPC
Install after DWV leak test	3114.2	
Individual fixture & branch AAV ≥4 in. above branch or fixture drain	3114.4	
Stack-type AAV min. 6 in. above FLR of highest fixture	3114.4	
Must be accessible for service & inspection & be open to airflow	3114.5	

FIG. 30 Trap Arms & Vents

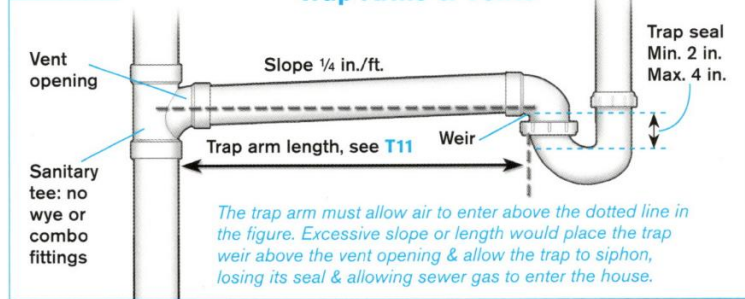

Island Sinks

	21 IRC	21 UPC
Air admittance valve under sink OK F36	3114.3	Ø
Special island vent only OK for sinks (IRC: & lavs) F31,32	3112.1	909.1
All fittings below FLR must be drainage type F31,32	3112.3	909.1

FIG. 31 UPC: Island Sink

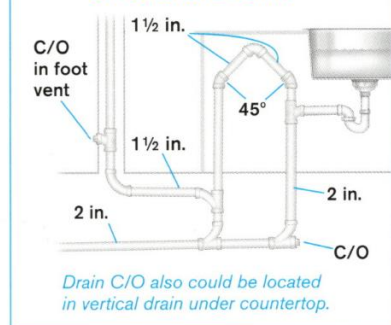
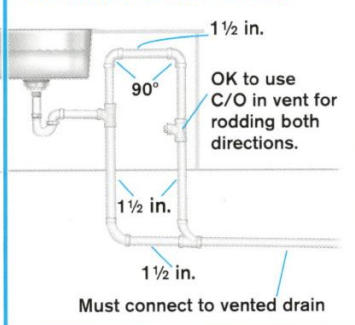

FIG. 32 IRC: Island Sink or Lav



Common Vents & Vertical Wet Vents

	21 IRC	21 UPC
Fixtures must be on same floor level	3107.1 & 3108.4	908.1&2
IRC: Size per DFUs discharging to wet vent T11,F33	3108.3	n/a
UPC: Min 2 in. & 1 pipe size larger than waste F34	n/a	908.1.1
UPC: Limited to trap arms of 1-DFU & 2-DFU fixtures	n/a	908.1
UPC: Max 4 fixtures to wet vent, max length 6 ft. F34	n/a	908.1

FIG. 33

IRC: Common Vent

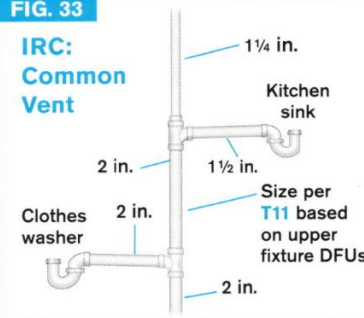
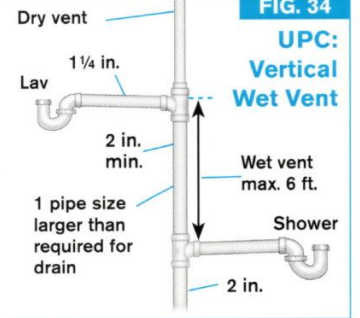

FIG. 34

UPC: Vertical Wet Vent



Horizontal Wet Vents

	21 IRC	21 UPC
Combinations of fixtures in up to 2 bath groups on same floor OK to be horizontally wet vented (UPC: 1 bath group)	3108.1	908.2
Fixture drains to horizontal wet vent must connect horizontally & independently, vertical connections require dry vent F35	3108.1	908.2
WC to wet vent downstream of other trap arm connections	n/a	908.2.4

FIG. 35

Horizontal Wet Venting

IRC allows up to 2 bath groups to be horizontally wet vented. The UPC allows only one bath group.

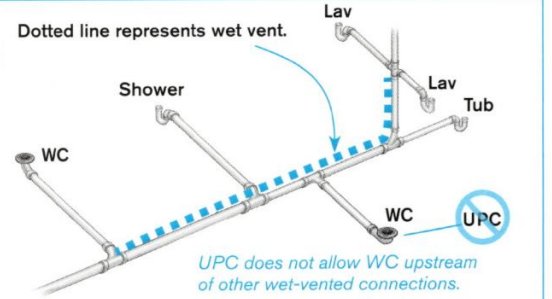
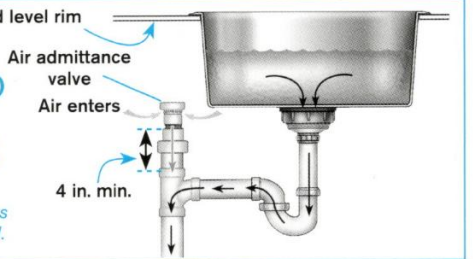

FIG. 36

IRC: Air Admittance Valve (AAV)

AAVs must remain accessible. When AAVs are placed in attics, they must be at least 6 in. above insulation. UPC does not allow AAVs unless specifically allowed by local AHJ.



Vent Termination

	21 IRC	21 UPC
Terminate through roof or sidewall (UPC: roof only)	3103.1.4	905.4
Min 6 in. above roof (IRC: or above snowline) EXC	3103.1.1	906.1
• 2 in. OK under solar array or architectural feature	3103.1.3	n/a
Min 4 ft. below (UPC: 10 ft.) or 3 ft. above doors, windows, or other air intakes within 10 ft. horizontally	3103.5	906.2
Exterior penetrations require watertight flashing	3103.3	906.5

WATER SUPPLY & DISTRIBUTION

Pipe Installation: General

21 IRC 21 UPC

- Mechanical ASSE 1010 water hammer arresters (not air chambers) required near quick-close valves (DW or CW) _____ 2903.5 609.11
- Dead legs must have method of flushing _____ n/a 309.6²⁹
- Flex connectors accessible (UPC: readily accessible) _____ 2906.7 604.5
- Burred ends to be reamed to full bore of pipe or tubing _ 2608.1 609.1

Size & Pressure

- Min water service 3/4-in. diameter pipe _____ 2903.7 610.8
- Provide required flow under peak demand & pressure **T14** 2903.1 610.8
- Size series systems based on pressure, losses for length, elevation, restrictive devices & demand in WSFUs _____ 2903.7 610.1&8
- Size parallel systems & manifolds per **T14,15** & AMI _____ 2903.8 610.4
- Install pressure booster if flow < **T14** (UPC: < 15 psi) _ 2903.3 608.1
- Install pressure-reducing regulator if pressure > 80 psi _ 2903.3.1 608.2
- Expansion tank (at WH) for closed systems (regulators or supplies w/ check valves) **F46** _____ 2903.4 608.2&3

TABLE 14 MIN CAPACITIES AT FIXTURE OUTLETS ◆ IRC T2903.1					
Fixture Outlet	Flow Rate (gpm)	Flow Pressure (psi)	Fixture Outlet	Flow Rate (gpm)	Flow Pressure (psi)
Bathtub	4	20	Shower	2.5	20
Bidet	2	20	Hose bibb	5	8
Dishwasher	2.75	8	Sink	1.75	8
Laundry tray	4	8	WC w/tank	3	20
Lavatory	0.8	8	WC 1-piece	6	20

FIG. 37

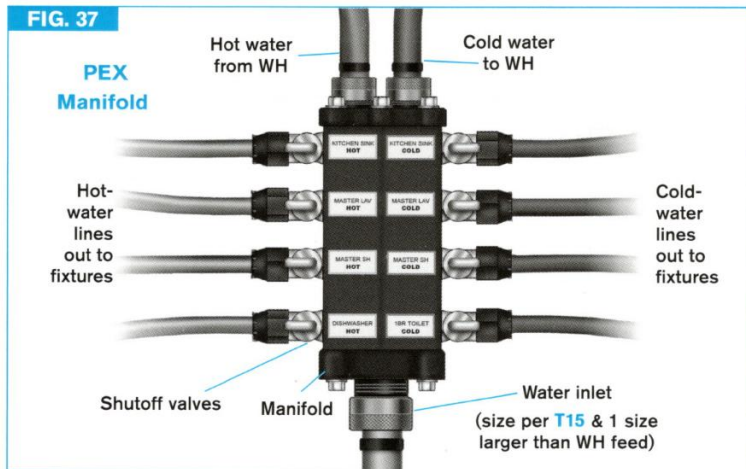

TABLE 15 MANIFOLD SIZING ◆ IRC T2903.8.1		
Inlet Pipe Size (in.)	Max. GPM Plastic ^A	Max. GPM Metal ^A
3/4	17	11
1	29	20
1 1/4	46	31
1 1/2	66	44

A. Based on velocity limitation of 12 ft./second for plastic & 8 ft./second for metal

Piping & Valves

21 IRC 21 UPC

- Polyethylene & PVC not OK for interior water distribution 2906.5 604.1
- Full-open shutoff @ main & WH **F38** _____ 2903.9.1&2 606.2
- Accessible shutoff each fixture & appliance EXC _____ 2903.9.3 606.5&6
 - Tubs & showers (UPC: fixtures w/o slip joints) _____ 2903.9.3 606.5
- Fixture valves at manifold if identified & accessible _____ 2903.8.4 606.5
- Water-hammer arresters required for quick-close valves _ 2903.5 609.10

FIG. 38

Shutoff & Flow Control Valves

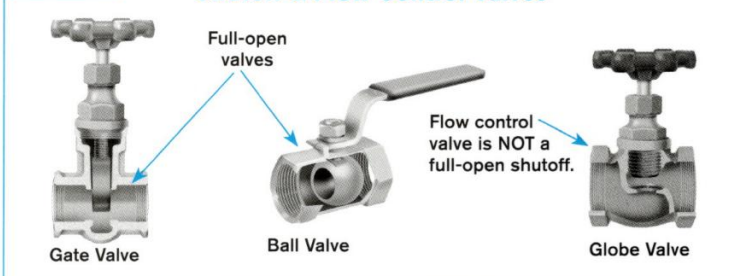

PEX Tubing

21 IRC 21 UPC

- Secure AMI & support per **T10** _____ 2903.8.3 313.3
 - Wrap or sleeve bundles at change of direction ≥ 45° _ 2903.8.3 MFR
 - Bend radius AMI _____ MFR MFR
 - No PEX within first 18 in. of tank-type WH _____ MFR 604.13
 - Handle & install PEX to ASTM F876-17 _____ 2906.5 604.1
- Do not store unprotected PEX tubing outdoors and exposed to sunlight.
 - Keep tubing & fittings in original packaging until time of installation.
 - Minimize sunlight exposure as recommended by MFR.
 - Maintain adequate distance between tubing and heat sources, such as light fixtures, flue vents, and heating appliances, so that the pipe surface temperature does not exceed 180°F.
 - Supports should allow free tubing movement for thermal expansion.
 - Tubing should not be pulled tight; allow slack for expansion/contraction.
 - Provide for expansion/contraction using offsets & expansion loops.
 - Min. bend radius 8× tubing diameter in direction of coil bend.
 - Do not use supports that pinch or cut the tubing.
 - Provide support near bends to prevent stress on fittings.

Protection of Potable Water Supply

- No connections between private & public water supply _ 2902.1 602.4
- Fixture outlet air gaps min 2× diameter of outlet _____ 2902.3.1 T603.3.1
- Backflow protection devices required @ hose bibbs (exc clothes washer), irrigation systems, or other source of contamination **F39** T2902.3 603.0

FIG. 39

Hose Bibb Backflow Protection



FIXTURES

General	21 IRC	21 UPC
<input type="checkbox"/> Fixtures, faucets, fittings listed to recognized standards	2701.1	301.2
<input type="checkbox"/> Hot on left, cold on right when facing outlet EXC	2722.2	417.5
• Single-handle tub or tub/shower controls per markings	2722.2X	417.5
<input type="checkbox"/> Smooth, impervious & no concealed fouling areas	2701.1	401.2
<input type="checkbox"/> Joint between fixtures & walls or floors watertight	2705.1(3)	402.2
Clearances F40		
<input type="checkbox"/> 15-in. min clearance from center of toilet or bidet to side wall, vanity, or adjacent fixtures	2705.1#5	402.5
<input type="checkbox"/> 21-in. (UPC: 24-in.) min clear in front of lav or toilet	2705.1#5	402.5
<input type="checkbox"/> Toilet & bidet min 30-in. separation center to center	2705.1#5	402.5

FIG. 40

Bathroom Fixture Layout

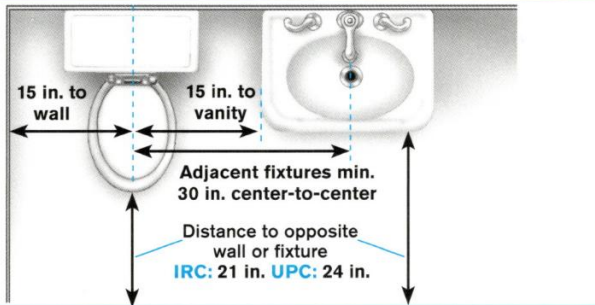

Toilet & Bidet	21 IRC	21 UPC
<input type="checkbox"/> Flange secured to floor & corrosion-resistant fasteners	2705.1#1	402.6.2
<input type="checkbox"/> Flange height AMI to finish floor, no fouling area	2701.1	402.6.1
<input type="checkbox"/> Max 1.6 gallons per flush (GPF) (check local rules)	2903.2	411.2
<input type="checkbox"/> Dual flush composite flush max 1.6 GPF, 2 low & 1 full	2903.2	411.2.1
<input type="checkbox"/> Ballcock critical level min 1 in. above overflow pipe	2902.4.1	603.5.2
<input type="checkbox"/> Max discharge temp at bidet 110°F	2721.2	410.3

Tubs	21 IRC	21 UPC
<input type="checkbox"/> Slip joint connections must be accessible F41	2704.1	402.10
<input type="checkbox"/> Slip joint access panel min 12 in. x 12 in. F41	2704.1	402.10
<input type="checkbox"/> Over-rim faucet vertical air gap min 2x outlet diameter	T2902.3.1	T603.3.1
<input type="checkbox"/> Vacuum breaker or integral protection for hose attachments	2708.5	417.4
<input type="checkbox"/> Temperature limiting device for tubs required at max 120°F, water heater thermostat may not be used to comply	2713.3	409.4
<input type="checkbox"/> Whirlpool pump accessible & above crown weir of trap	2720.2	409.6
<input type="checkbox"/> Whirlpool tub pump requires removable access panel AMI	2720.1	409.6
<input type="checkbox"/> Opening ≥ 12 in. x 12 in., 18 in. x 18 in. if >2 ft. from access	2720.1	n/a

FIG. 41

Slip Joints & Access

Min. 12-in. x 12-in. access for concealed slip joints or jetted tub pumps to allow repair or replacement. Access can be through the wall or the ceiling.

IRC requires min. 18-in. x 18-in. access where jetted pump is set back more than 24 in. from access opening.

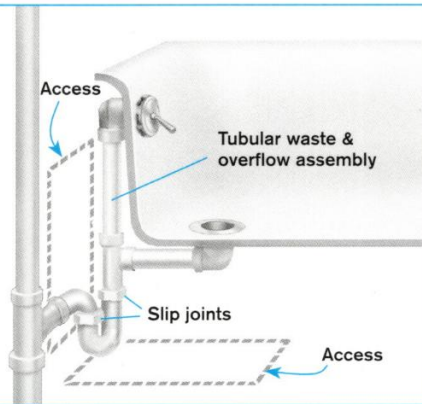

Showers	21 IRC	21 UPC
<input type="checkbox"/> Max flow rate 2.5 gpm @ 80psi	T2903.2	408.2
<input type="checkbox"/> Min 24-in. clearance in front of shower opening	307.1	n/a
<input type="checkbox"/> Nonabsorbent surface to 72 in. (UPC: 70 in.) above floor	307.2	local
<input type="checkbox"/> Door min 22-in. unobstructed opening for egress	2708.1&1.1	408.5
<input type="checkbox"/> Showerhead not to discharge at shower entrance	local	408.9
<input type="checkbox"/> Temperature limiting device set at max 120°F	2708.4	408.3
<input type="checkbox"/> Riser from valve to showerhead securely attached	2708.3	408.10
<input type="checkbox"/> Min area 900 sq. in. (UPC: 1,024 sq. in.) to 70 in. high	2708.1	408.6
<input type="checkbox"/> 30-in. min interior shower dimension to wall surfaces EXC	2708.1	408.6
• 25-in. OK if area ≥ 1,300 sq. in. (UPC 30 in. x 60 in.)	2708.1X2	408.6X2
<input type="checkbox"/> If threshold provided, min 2 in. max 9 in. above drain	2709.1	408.5

Shower Pans

<input type="checkbox"/> Pan liner plastic AMI or 3 layers hot mop type 15 felt	2709.2	408.7
<input type="checkbox"/> Other approved materials/coatings AMI	2709.2	408.7
<input type="checkbox"/> Liner min 2 in. above dam or threshold (UPC: 3 in.)	2709.2	408.7
<input type="checkbox"/> No fasteners < 1 in. above dam or threshold	2709.3	408.7
<input type="checkbox"/> Slope lining 1/4-1/2 in./ft. toward drain	2709.3	408.7
<input type="checkbox"/> Slope finish floor 1/4-1/2 in./ft. to drain (UPC: 1/8-1/2 in./ft.)	2709.1	408.5
<input type="checkbox"/> Weep holes at drain must remain clear	2709.4	408.7

Laundry

<input type="checkbox"/> Standpipe min 18 in., max 42 in. (UPC: 30) above trap	2706.1.2	804.1
<input type="checkbox"/> Trap min 6 in., max 18 in. above floor	n/a	804.1
<input type="checkbox"/> IRC laundry tub may drain to standpipe within 30 in.	2706.1.2.1	local

Outdoors

<input type="checkbox"/> Nonremovable vacuum breaker F39 hose bibbs EXC	2902.4.3	603.5.7
• Water heaters or boiler drain, laundry connections	2902.4.3X	603.5.7
<input type="checkbox"/> Backflow protection required on lawn irrigation systems	2902.5.3	603.5.6.
<input type="checkbox"/> Vacuum breaker 6 in. above highest sprinkler head	2902.3.2	T603.2
<input type="checkbox"/> PVC exposed to sunlight max 24 in. & UV protective tape	n/a	605.12
<input type="checkbox"/> Freezing climates "frostproof" hose bibbs require stop-&-waste or stem extending to semi-conditioned space	2903.10	603.4.7

Kitchen

<input type="checkbox"/> Drainage air gap device above FLR for DW drain F42	n/a	807.3
<input type="checkbox"/> Secure drain hose to underside of counter F43	2717.2	n/a
<input type="checkbox"/> DW drain through wye fitting or to disposer head	2717.2	404.1

FIG. 42

UPC: Air Gap Required

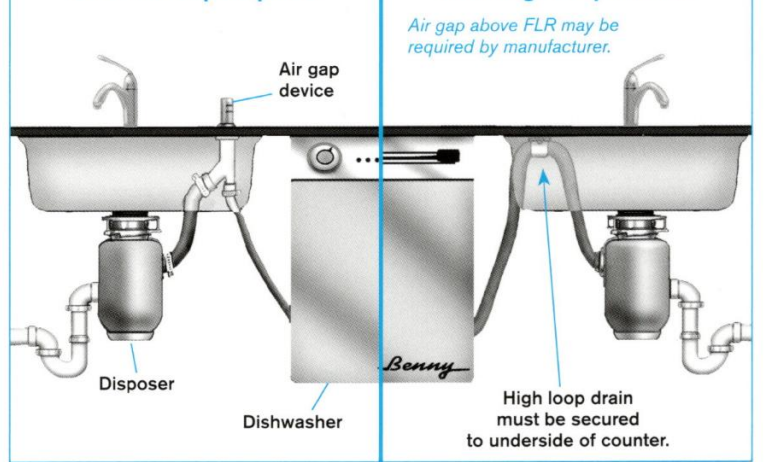

FIG. 43

IRC: High Loop Allowed

Air gap above FLR may be required by manufacturer.

High loop drain must be secured to underside of counter.

WATER HEATERS

General	21 IRC	21 UPC
<input type="checkbox"/> Permit required for new or replacement WH _____	105.1	502.1
<input type="checkbox"/> Full-open valve required on cold water supply F45 _____	2903.9.2	606.2
<input type="checkbox"/> Unions required within 12 in. of tank for service and removal _____	n/a	609.5
<input type="checkbox"/> Gas WH: Use only 1 draft hood that is supplied w/ WH _____	2448.1	501.1
<input type="checkbox"/> Secure vent or connector to draft hood _____	2427.10.6	509.10.5
<input type="checkbox"/> Electric WH: Disconnect within sight or lockable _____	T4101.5	see p. 28

Location		
<input type="checkbox"/> Fuel-fired WH prohibited in storage closets _____	2005.2 & 2406.2	n/a
<input type="checkbox"/> Fuel-fired WHs in bed- or bathrooms direct-vent or dedicated closet w/self-closing door & exterior air (p. 21) _____	2005.2 & 2406.2	504.1
<input type="checkbox"/> Ignition source ≥ 18 in. above garage floor EXC _____	2801.7	507.13
• Flammable-Vapor Ignition-Resistant (FVIR) WH _____	2801.7X	507.13
<input type="checkbox"/> Vehicle protection (location or bollards) required in garage _____	1307.3.1	507.13.1
<input type="checkbox"/> Min 3-in. concrete base if supported directly on ground _____	1305.1.3.1	507.4
<input type="checkbox"/> Outdoor enclosure required unless WH listed for outdoors _____	MFR	507.25
<input type="checkbox"/> SDC D & SDC C townhouses (UPC: all SDC C, D & E) seismic restraint straps in upper & lower 1/3 of tank F45 _____	2801.8	507.2

Pan F45		
<input type="checkbox"/> Required if leaks would cause damage _____	2801.6	507.5
<input type="checkbox"/> IRC: not required under tankless WHs; UPC: required _____	2801.6	507.5
<input type="checkbox"/> Drain pipe min 3/4 in. to indirect waste or on building exterior 6–24 in. above grade (UPC: to approved location) _____	2801.6.2	507.5
<input type="checkbox"/> Plastic pans under gas-fired WH flame spread index ≤ 25, smoke-developed index ≤ 450 per UL 723 _____	2801.6	n/a

Access & Working Space		
<input type="checkbox"/> Provide access & working space (IRC min 30 in. x 30 in.) _____	2801.4	507.26
<input type="checkbox"/> Access path and door size min 24 in. wide _____	1305.1.1	508.4.2
<input type="checkbox"/> Attic floor max 20 ft., min 24 in. wide _____	1305.1.2	508.4.2
<input type="checkbox"/> Light & recep outlet near attic WHs _____	1305.1.2.1	508.4.4

Tankless (On Demand) Water Heaters F44		
<input type="checkbox"/> Size gas line to max input Btu rating _____	2413.1	1214.2
<input type="checkbox"/> Install AMI (PRV usually specified), vent typical Type III or IV _____	2005.1	501.1
<input type="checkbox"/> Vent clearances F57 _____	2427.8	509.8.2

FIG. 44

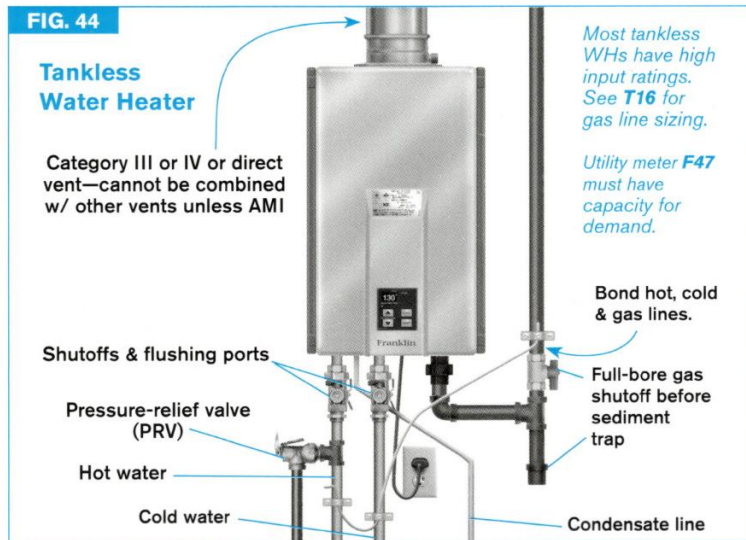
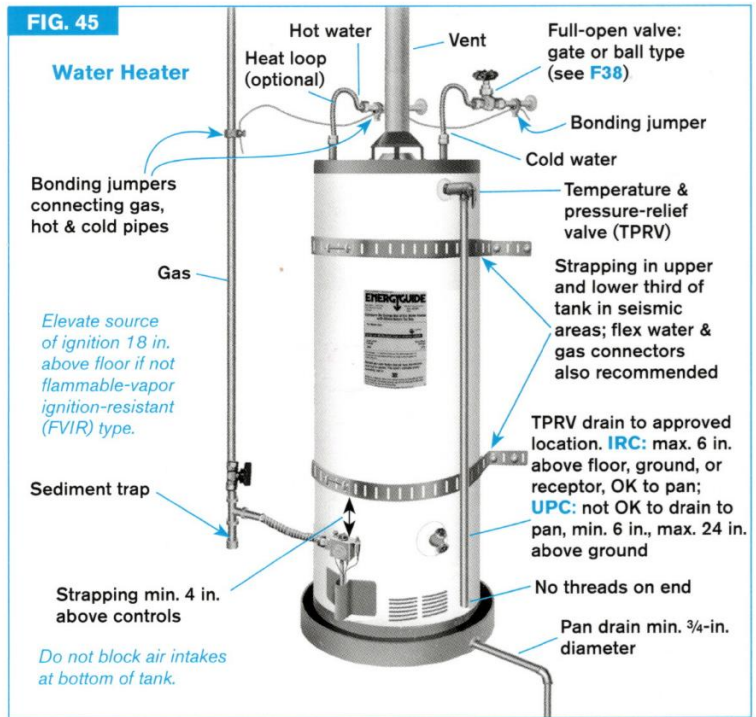

FIG. 45



Temperature & Pressure-Relief Valves (TPRV) 21 IRC 21 UPC		
<input type="checkbox"/> Combination TPRV (required in UPC) or _____	2804.1	608.3
• Separate TRV (e.g.: Watts 210 gas valve) and PRV _____	2804.1	504.4&5
<input type="checkbox"/> Locate TPRV AMI F45,46 _____	2804.3&4&5	608.3

TPRV Discharge Pipe F45		
<input type="checkbox"/> No shutoff or check valves before or after TPRV _____	2804.6	504.6
<input type="checkbox"/> Size at least same as TPRV outlet _____	2804.6.1	608.5
<input type="checkbox"/> End pointing downward and w/ no threads _____	2804.6.1	608.5
<input type="checkbox"/> End in readily observable location _____	2804.6.1	608.5 ³⁰
<input type="checkbox"/> End outside or other approved location _____	2804.6.1	608.5
<input type="checkbox"/> End above ground or receptor min. 2 pipe diameters max. 6 in.;		
UPC: 6–24 in. from ground, floor, or receptor _____	2804.6.1	608.5
<input type="checkbox"/> May not run uphill or be trapped _____	2804.6.1	608.5
<input type="checkbox"/> May discharge to WH pan (UPC: prohibited) _____	2804.6.1	608.5

FIG. 46

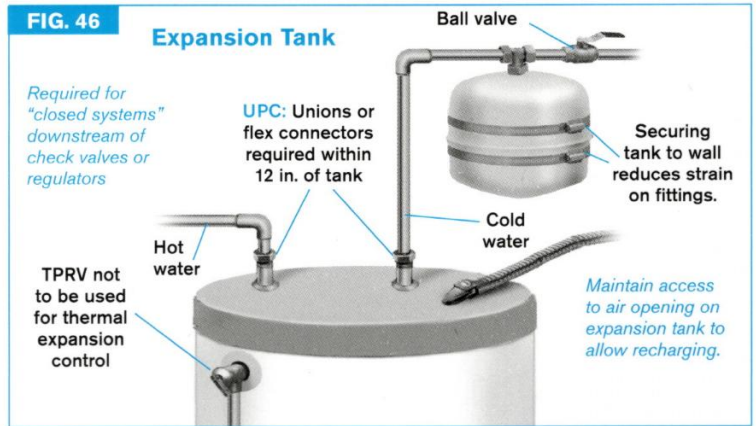

GAS PIPING

For underground gas pipes, see p. 15.

General 21 IRC 21UPC

- Locate gas meter in accessible & ventilated space _____ utility 1208.7.1
- Main shutoff at each meter & building **F47** _____ 2420.2&3 1210.9.3
- Install CSST AMI (includes training & qualification) _____ 2415.2 1208.6.4.4
- Size Fe or poly pipe per tables **T16,17**; size CSST AMI _____ 2413.3 1215.1
- Support pipe & smooth-wall tubing per **T18**, CSST AMI _____ 2424.1 1210.2.4.1

Appliance Shutoffs & Connections

- Valve ahead of union & ≤6 ft. of appliance **F44,45** EXC 2420.5.1 1212.6
 - 50 ft. OK if accessible identified valve at manifold _____ 2420.5.3 ∅
- Flex connector (UPC min practical length &) max 6 ft. 2422.1.2.1 1212.6
- No flex through walls, floors, ceilings, or appliance EXC 2422.1.2.3 1212.5.3
- Protective grommet if through appliance wall _____ 2422.1.2.3X4 1212.1
- Sediment trap required after appliance shutoff valve & as close as practical to appliance EXC **F44,45** _____ 2419.4 1212.9³¹
 - Ranges, clothes dryers, fireplaces & gas lights _____ 2419.4 1212.9

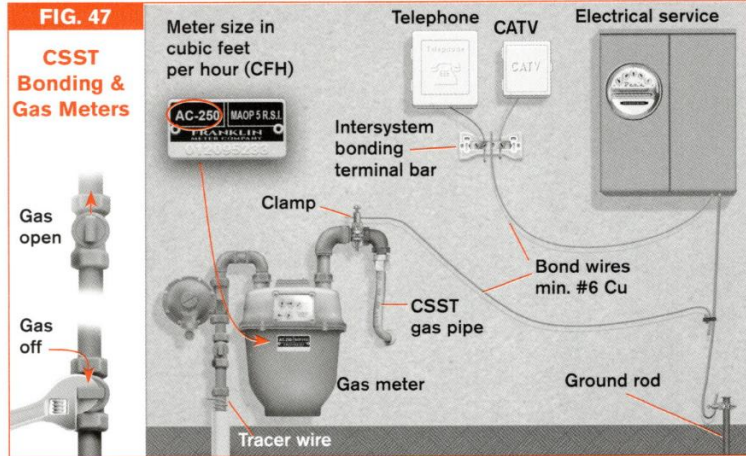

Electrical Bonding 21 IRC 21UPC

- Electrically bond above-ground metal gas pipes **F45,47** _____ 3609.7 1211.1
- Appliance EGC sufficient to bond non-CSST gas pipe _____ 3609.7 1211.1
- Bond CSST to grounding electrode system w/L&L UL 467 fitting, min #6 wire, max length 75 ft. **F47** EXC _____ 2411.2.3 1211.2
 - L&L arc-resistant CSST that forms fault current path **2411.3³²** 1211.3³²
- CSST bonding jumper min #6 Cu **F47** _____ 2411.2.2 1211.2.2

TABLE 16 SIZE PROCEDURES ♦ IRC 2413.4.1&2 UPC 1215.1.1&2

1. Determine Btu/cu. ft. gas from local supplier (usually 1100).
2. Divide appliance Btu by Btu/cu. ft. to obtain appliance demand.
3. (Longest length method) Measure developed length to most remote outlet.
4. (Longest length method) Use column from **T17** for most remote fixture for all outlets.
5. Select row for pipe size equaling or exceeding demand each section.

TABLE 17 Fe GAS PIPING ♦ IRC T2413.4(1) & UPC T1215.2(1)

Pipe	Length (in feet)											
	10	20	30	40	50	60	70	80	90	100	125	150
Demand Capacity (in cu.ft./hour)												
½ in.	172	118	95	81	72	65	60	56	52	50	44	40
¾ in.	360	247	199	170	151	137	126	117	110	104	92	83
1 in.	678	466	374	320	284	257	237	220	207	195	173	157
1¼ in.	1390	957	768	657	583	528	486	452	424	400	355	322
1½ in.	2090	1430	1150	985	873	791	728	677	635	600	532	482

TABLE 18 GAS PIPE SUPPORT ♦ IRC T2424.1 UPC T1210.2.4.1

Steel Pipe Nominal Size (in.)	Max. Support Spacing (ft.)	Smooth-Wall Tubing Nominal Size (in.)	Max. Support Spacing (ft.)
½	6	½	4
¾ or 1	8	¾ or 1	6
≥ 1¼ (horizontal)	10	¾ or 1 (horizontal)	8
≥ 1¼ (vertical)	Every floor level	≥ 1 (vertical)	Every floor level

GAS APPLIANCE COMBUSTION AIR (C/A)

General 21 IRC 21 UMC

- C/A required for fuel-burning appliances EXC _____ 2407.1 701.1
 - Direct-vent appliances installed AMI _____ 2407.1 701.1X1
- Make-up air required to offset exhaust fans _____ 2407.4 701.3

Indoor Air Source

- Not allowed when BTE has known ACH <0.40 _____ 2407.5 701.4
- Min volume of space 50 cu.ft./1kBtu/hour **F48** _____ 2407.5.1 701.4.1
- Indoor air volume includes rooms directly communicating w/ appliance space **F48** _____ 2407.5 701.4
- Openings connecting indoor spaces min 100 sq. in. & min 1 sq. in. /1kBtu upper & lower 12 in. of appliance space **F48** _____ 2407.5.3.1 701.5

Openings

- Outside air openings screens w/ mesh ≥¼ in. _____ 2407.10 701.10.1
- Where net free area of louvers not known, assume 75% for metal louvers, 25% for wood louvers _____ 2407.10 701.10

Exterior Air Source

- 2 direct exterior openings upper & lower 12 in. **F49** _____ 2407.6.2 701.6.2
- Single opening direct to exterior OK upper 12 in. **F49** _____ 2407.6.2 701.6.2

FIG. 48

Combustion Air from Indoor Spaces

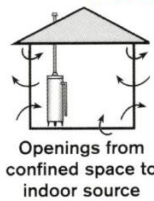

Combustion Air from Exterior Openings

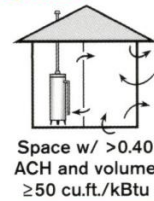

1 opening in upper 12 in. of exterior wall min. 1 sq.in./3kBtu



2 openings min. 1 sq.in./4kBtu each

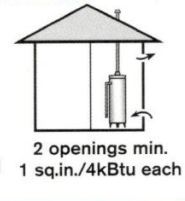

FIG. 49

Combustion Air Ducts 21 IRC 21 UMC

- No screens allowed on ducts terminating in attic _____ 2407.11#5 701.11#5
- Duct galv metal or material of equivalent performance _____ 2407.11 701.11
- Joist/stud space as C/A duct ≤1 fireblock removed _____ 2407.11X 701.11X
- Exterior openings ≥12 in. above finished ground **F50** 2407.11#8 701.11
- Upper & lower ducts remain separate to source _____ 2407.11 701.11
- Ventilated attics & crawl = outdoors **F51** _____ F2407.6.1(1&2) F701.6.1&2

FIG. 50

Combustion Air Ducts

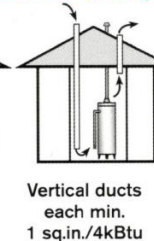

Air from Spaces Equivalent to Outdoors

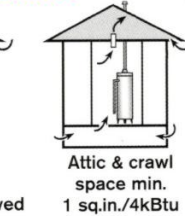
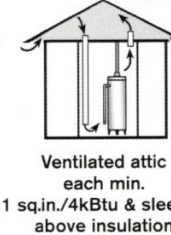

FIG. 51

APPLIANCES & EQUIPMENT

General	21 IRC	21 UMC
<input type="checkbox"/> Equipment must be L&L or approved as equivalent by AHJ 1302.1		301.2
<input type="checkbox"/> Install listed equipment AMI _____ 1307.1 & 1401.1 & 2408.1		303.1
<input type="checkbox"/> Attach installation instructions to appliance ___ 1307.1 & 2408.1		303.1
<input type="checkbox"/> Install above design flood elevation _____ 1401.5		305.3
<input type="checkbox"/> Air filter(s) required for heating & cooling air systems _____ MFR		311.2
<input type="checkbox"/> Habitable room heating source must be capable of maintaining 68°F 3 ft. above floor @ 2-ft. distance from exterior walls_ 303.10		local
<input type="checkbox"/> Portable space heaters not an acceptable heating source 303.10		local
Electrical		
<input type="checkbox"/> Electrical disconnect within sight or per electrical code _ T4101.5		301.4
<input type="checkbox"/> Recep within 25 ft. on same level as appliance F52 _ 1305.1.2.1		301.4
<input type="checkbox"/> No recep outlets on load side of appliance disconnect _ 3901.12		p. 28
<input type="checkbox"/> Light near attic or crawlspace appliances F52 _ 1305.1.2.1&1.3.3		304.4.4
<input type="checkbox"/> Light switch located at passageway entry opening _ 1305.1.2.1		304.4.4
<input type="checkbox"/> Exposed lamps protected by location or lamp guard F52 1305.1.2.1		n/a

APPLIANCE LOCATIONS

Access & Clearances	21 IRC	21 UMC
<input type="checkbox"/> Gas-fired not OK in bedroom, bath, or their closets EXC 2406.2		904.1
• Direct-vent type _____ 2406.2(1)		904.1(2)
• Closet w/ exterior C/A & gasketed self-close door __ 2406.2(5)		904.1(1)
<input type="checkbox"/> Min 30-in. x 30-in. work area service side of appliance_ 1305.1		304.1
<input type="checkbox"/> Locate so as to allow access for appliance service _____ 1305.1		304.1
<input type="checkbox"/> Min 24-in-wide opening to allow appliance removal ___ 1305.1.1		n/a
<input type="checkbox"/> Install w/ clearances to combustibles AMI _____ 1306.1		303.1
Underfloor & Attic		
<input type="checkbox"/> Appliance must fit through access opening _____ 1305.1.2		304.4
<input type="checkbox"/> Support slab/platform min 3 in. above ground _ 1305.1.3.1 & 2408.4		904.3.1.1
<input type="checkbox"/> Suspended equipment min 6 in. above ground 1305.1.3.1 & 2408.4		904.3.1.2
<input type="checkbox"/> Passageway min 22 in. wide x 30 in. high _____ 1305.1.2&3		304.4
<input type="checkbox"/> Passageway max distance 20 ft. if < 6 ft. high _____ 1305.1.2&3		304.4.1
<input type="checkbox"/> Attic: solid floor min 24 in. wide to equipment _____ 1305.1.2		304.4.2
<input type="checkbox"/> Min 30-in. x 30-in. platform at service side EXC ___ 1305.1.2&3		304.4.3
• If equipment can be serviced from attic opening _ 1305.1.2X1		304.4.3X
(UMC: max setback from attic opening 12 in.) _____ n/a		304.4.3X
Garage		
<input type="checkbox"/> Protect appliance from impact _____ 1307.3.1 & 2408.3X		305.1.1
<input type="checkbox"/> Ignition source min 18 in. above floor EXC ___ 1307.3 & 2408.2		305.1
• Listed flammable-vapor ignition-resistant _ 1307.3 & 2408.2X		305.1
• Separate enclosed area w/ outside access & C/A _ 2408.2.1		305.1.2
<input type="checkbox"/> Duct penetrations of garage/dwelling min 26-gauge steel & no openings into garage _____ 302.5.2, 1601.4.9		local

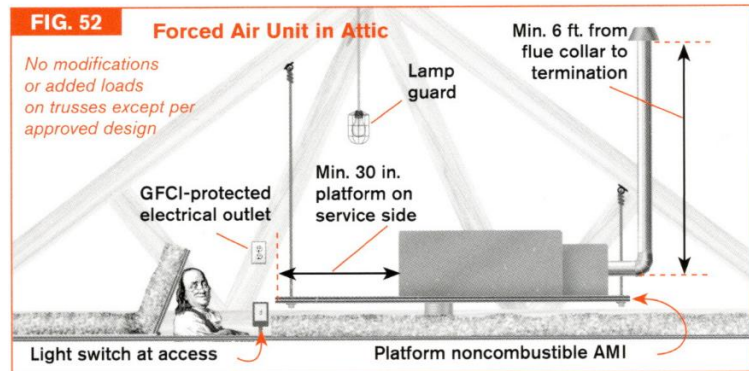

DUCTS

General	21 IRC	21 UMC
<input type="checkbox"/> Size per ACCA Manual D or other approved method _____ 1601.1		601.2X
<input type="checkbox"/> Factory-made ducts L&L per UL 181 & installed AMI F54 1601.1.1		603.4
<input type="checkbox"/> Max. 2 stories for vertical riser on factory-made duct _____ n/a		603.1.4
<input type="checkbox"/> Fireblocking at annular space around duct penetrations between floors (UMC: not to penetrate fire-resistance-rated assembly) _ 302.11		605.1.2
Return Air		
<input type="checkbox"/> Must be from space \geq 25% of area served or from space w/ openings to spaces \geq 25% of area served _____ 2442.3(4)		311.3
<input type="checkbox"/> Not from area of objectionable odors or vapors (closet, bathroom, kitchen, garage, mechanical room, or attic) _____ 1602.2 & 2442.3		311.3
<input type="checkbox"/> Min 10 ft. from draft hood or vent outlet _____ 1602.2 & 2442.3		311.3
<input type="checkbox"/> No return air from one dwelling unit to another _ 1602.2 & 2442.5		311.4
Installation		
<input type="checkbox"/> Ground clearance min 4 in. _____ 1601.4.8		603.1.3
<input type="checkbox"/> 18-in. vertical clearance where needed under duct to prevent cutting off access to crawlspace _____ n/a		603.2
<input type="checkbox"/> Duct supports AMI or per SMACNA standards F53 _____ 1601.4.4		603.3&4
<input type="checkbox"/> Flex support interval max 4 ft. horizontal, 6 ft. vertical F53 _____ n/a		603.4
<input type="checkbox"/> Existing building stud cavities OK as return (not supply) if no condensation, max 125°F & not from one floor to another 1601.1.1		602.2&5
<input type="checkbox"/> New construction not OK to use stud cavity as duct ___ 1103.3.5		local
Joints & Seams		
<input type="checkbox"/> Metal-duct crimp joints contact lap min 1 in. (UMC: 1 1/2 in.) & fasten w/ min 3 sheet-metal screws _____ 1601.4.1		603.9
<input type="checkbox"/> Duct joints sealed airtight per SMACNA standards & w/ mastics & pressure-sensitive tapes L&L to UL 181B _____ 1601.4.1		603.9
<input type="checkbox"/> Duct leakage test (IRC: max differential 0.1 in w.g.) _____ 1103.3.5		603.9.2
Insulation in Unconditioned Space (1-in. fiberglass \approx R-3)		
<input type="checkbox"/> R-value marked on exterior of insulation _____ 1101.10.2		605.1
<input type="checkbox"/> Ducts < 3 in. diameter R-6 min in attics, R-4.2 elsewhere 1103.3.1		local
<input type="checkbox"/> R-8 min in attics, R-6 elsewhere EXC _____ 1103.3.1		local
• Ducts completely inside BTE _____ 1103.3.2		605.1X2

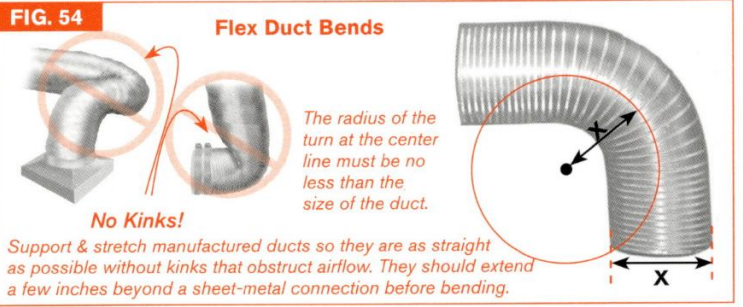
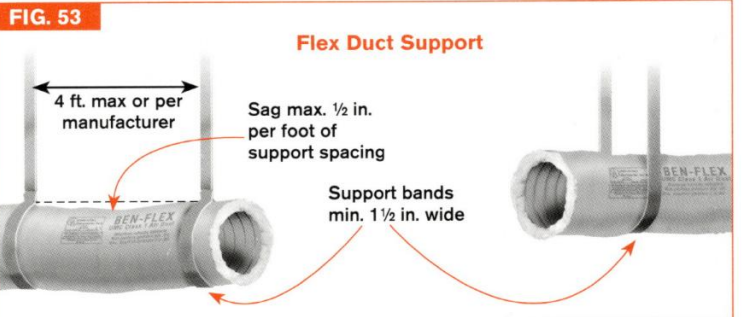

VENTING

- General** **21 IRC** **21 UMC**
- System must convey combustion gases to outdoors _____ 2427.3 802.3
 - Vents L&L except single-wall or plastic per MFR _____ 2426.1 802.1
 - Select vent system type per appliance category & MFR **T19** 2427.4 802.4
 - Install all venting systems AMI _____ 2426.5 802.6
 - Category I fan-assisted per MFR-supplied tables _ 2427.6.9.1(1) 802.6.2.1
 - Vent no smaller than draft hood & not >7× larger _ 2427.6.9.1(2) 802.6.2.1
 - Draft-hood appliance 1 60° offset OK, others ≤45° EXC 2427.6.9.2 802.6.3.2
 - Fan-assisted: use MFR-supplied vent tables _____ 2427.6.9.1(1) 802.6.2.1
 - Insulation shield min 2 in. above attic insulation & AMI _ 2426.4 802.6.1.1
 - Concealed vents <1½ in. from face of framing require protection, min 16-gauge metal shield extending ≥4 in. beyond plates 2426.7 MFR

TABLE 19 APPLIANCE VENTING CATEGORIES ◆ IRC 2403 UMC 224			
Category	Condensation	Static Pressure	Typical Vent
I	No	Nonpositive	B Vent
II	Yes	Nonpositive	Per MFR
III	No	Positive	Per MFR (Stainless Steel)
IV	Yes	Positive	Per MFR (Plastic)

- Vent Connectors** **21 IRC** **21 UMC**
- Connector required unless direct-attached vent 2426.2&2427.10.1 802.10
 - Joints & connections require screws or AMI _____ 2427.10.6 802.10.5
 - Clearance to combustibles 6 in. for single-wall _____ 2427.10.5 802.7.3.3
 - Slope upward min ¼ in./ft. toward vent **F55** _____ 2427.10.8 802.10.6
 - Single-wall connector max run 75% of vertical rise _ 2427.10.9 802.10.7.1
 - Type B connector max run 100% of vertical rise _____ 2427.10.9 802.10.7.2
 - No single-wall in unconditioned attics or crawlspaces 2427.10.2.2 802.10.1.1
 - No single-wall through interior wall, floor, ceiling _____ 2427.10.14 802.10.12

Appliances with Common Venting

- 2 draft-hood-equipped appliances: common vent or common connector must be ≥ largest connector/draft hood + 50% of smaller flue collar outlet 2427.6.9.1(3) & 2427.10.3.4 802.10.2.3
- Join smaller connector to common vent at highest level consistent w/ available headroom & required clearances **F55** _____ 2427.10.4 802.10.3.1
- Connectors ≤45° of vertical OK at same level **F55** _____ 2427.10.4.1 802.10.3
- Junctions w/ tee or wye MFR for the purpose **F55** _ 2427.10.7³³ n/a

FIG. 55

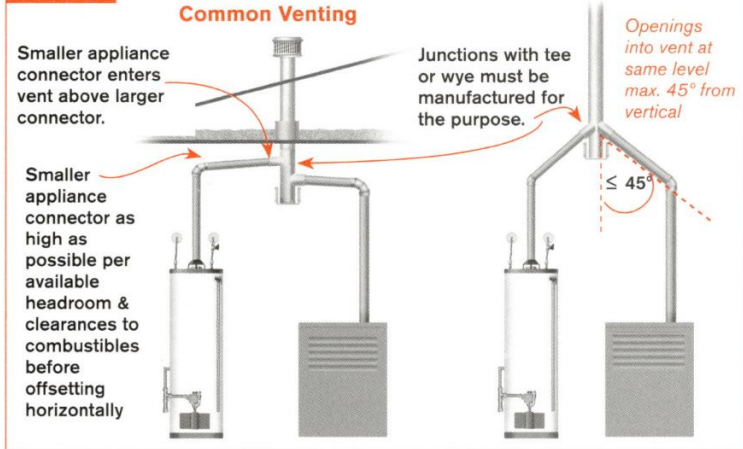

- Gas Vent Entering Masonry Chimney** **21 IRC** **21 UMC**
- No common venting solid fuel & gas appliances _____ 2427.5.6.1 802.5.8
 - Must be lined w/ clay or metal EXC _____ 2427.5.1.34 802.5.7.1
 - Like-for-like appliance if chimney passes inspection _____ Ø34 802.5.7.1X
 - Cross-sectional area ≤7× size of draft hood outlet _ 2427.5.4(2) 802.5.5(2)
 - Height & clearances above roof – see p. 12

Single-Wall Vent

- Not allowed in dwellings & residential occupancies _____ n/a 802.7.3
- Run from appliance space directly to outside _____ 2427.7.4 802.7.3.1
- May not originate in attic or pass through inside wall _____ 2427.7.6 802.7.3.2
- Clearance to combustibles min 6 in. _____ 2427.7.8 802.7.3.3

B Vent Termination

- Extend above roof & min 5 ft. above flue collar EXC _____ 2427.6.5 802.6.1
 - 6 ft. for fan-assisted Category I appliances _____ 2428.2 803
- If vertical surface within 8 ft., vent must terminate min 2 ft. higher than any part of building within 10 ft. horizontal **F56** _____ 2427.6.4 802.6.2
- Min height above roofs **T20** _____ 2427.6.4 802.6.2

FIG. 56

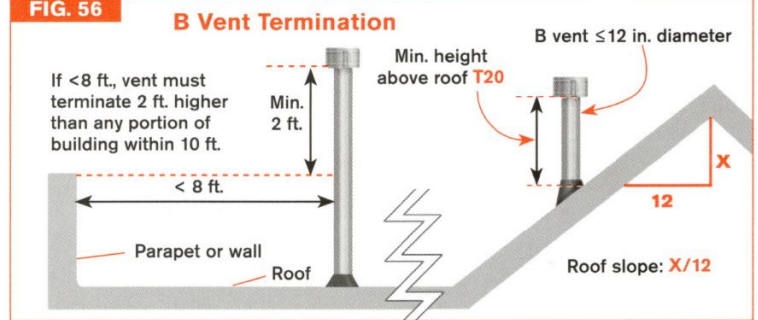

TABLE 20 B VENT TERMINATION ◆ IRC T2427.6.4 UMC T802.6.1

Roof Slope	Min. Height (ft.)	Roof Slope	Min. Height (ft.)
Flat to 6/12	1	> 11/12 to 12/12	4
> 6/12 to 7/12	1¼	> 12/12 to 14/12	5
> 7/12 to 8/12	1½	> 14/12 to 16/12	6
> 8/12 to 9/12	2	> 16/12 to 18/12	7
> 9/12 to 10/12	2½	> 18/12 to 20/12	7½
> 10/12 to 11/12	3¼	> 20/12 to 21/12	8

Forced Draft Systems (Cat. III & IV)

- Forced draft systems L&L & installed AMI _____ 2427.3.3(1) 802.3.3
- Forced draft system must be gas-tight _____ 2427.3.3(3) 802.3.3.2
- MFR instructions must identify specific plastic type _____ 2427.4.1 802.4.1
- Plastic joint primers must be contrasting color _____ 2427.4.1.1 802.4.2
- No common venting natural & forced-draft systems _____ 2427.3.3(4) 802.3.3.3
- Terminate min 4 ft. to side or below or 1 ft. above building openings & min 1 ft. above ground level _____ 2427.8(2) 802.8.1
- Cat. IV vents in outside wall min 10-ft. horizontal separation to openings in adjacent building unless 2 ft. above or 25 ft. below _____ 2427.8 802.8.5
- Collect & dispose of condensate from vent _____ 2427.9 802.9

Direct Vent Termination: Clearance to Openings

- 0-10 kBtu/hr min 6 in., >10-50 kBtu/hr min 9 in., >50 kBtu/hr min 12 in. _____ T2427.8 802.8.2
- >150kBtu/hr AMI & min 4 ft. horizontal or below openings or 1 ft. above openings **F57** _____ T2427.8 MFR

FIG. 57

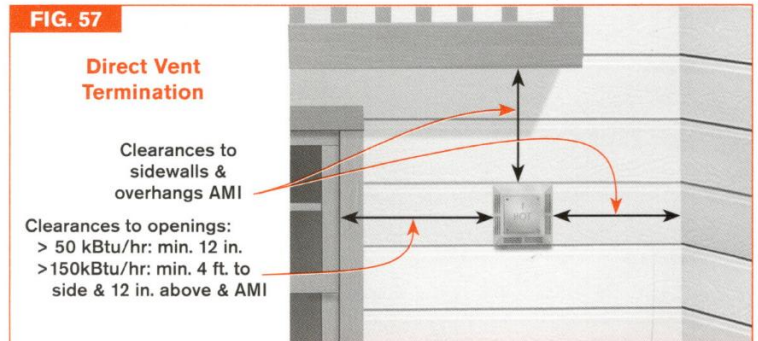

APPLIANCES

AC Condensers & Heat Pumps	21 IRC	21 UMC
<input type="checkbox"/> Working space on control side min 30 in. x 30 in. _____	1305.1	304.1
<input type="checkbox"/> Evaporator downstream of heat exchanger unless AMI _____	1411.2	904.7
<input type="checkbox"/> Outdoor units on raised base ≥3 in. above ground F68 _____	1401.4	1105.2
<input type="checkbox"/> Tamper-resistant caps on outdoor refrigerant ports _____	1411.9	1105.11
<input type="checkbox"/> Insulation (min R-3) & vapor retarder on suction lines _____	1411.6	1109.9
<input type="checkbox"/> Secure in place (including seismic restraint) _____	1307.2	303.4
<input type="checkbox"/> Electrical disconnect within sight F68 _____	T4101.5	301.4
<input type="checkbox"/> Secure refrigerant tubing within 6 ft. of condensing unit _____	1411.8 ³⁵	1109.6

Condensate Control (AC & Condensing Furnaces) F58		
<input type="checkbox"/> Primary drain trapped AMI _____	1401.1	310.5
<input type="checkbox"/> Convey condensate to approved location (UMC: through air break or air gap to dry well or plumbing fixture tailpiece) _____	1411.3	310.5
<input type="checkbox"/> Drain min 3/4 in. w/ min 1/8 in./ft. slope _____	1411.3.1&2	310.1&3
<input type="checkbox"/> Drains require cleanouts _____	1411.3.3	310.3.1
<input type="checkbox"/> Where stoppage/overflow would cause damage, provide one of following:		
• Auxiliary pan w/ drain pipe under equipment _____	1411.3.1(1)	310.2(2)
• Secondary drain line higher than primary drain _____	1411.3.1(2)	310.2(3)
• Auxiliary pan w/ interlocked detector & no drain _____	1411.3.1(3)	310.2(4)
• Water-level detection device w/ interlock _____	1411.3.1(4)	310.2(1)
<input type="checkbox"/> Secondary drains to readily observed location _____	1411.3.1(1&2)	310.2
<input type="checkbox"/> Blockage detector in primary pan of downflow units _____	1411.3.1.1	904.7
<input type="checkbox"/> Pumps only allowed to lift vertically to gravity drain _____	n/a	310.1.1
<input type="checkbox"/> Pumps interlocked to appliance (IRC: if in attic or crawl) _____	1411.4	310.1.1

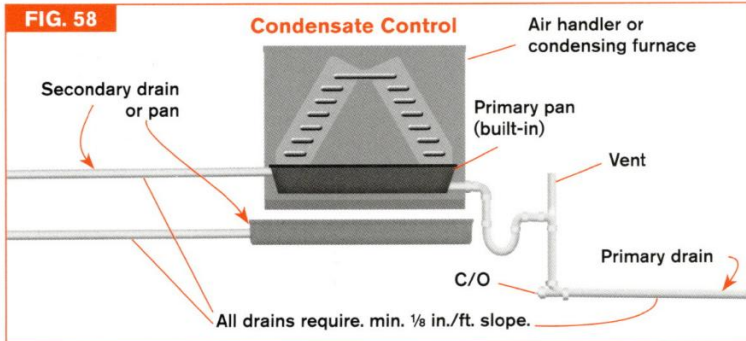

Gas Wall Furnaces	21 IRC	21 UMC
<input type="checkbox"/> Install AMI _____	2436.1	907.1
<input type="checkbox"/> Clearance to prevent ignition hazards _____	2436.3	907.2
<input type="checkbox"/> Door swing (IRC: min 12 in.) not to cause hazard _____	2436.4	907.2
<input type="checkbox"/> Room or space must have adequate combustion air _____	2407.5	907.3
<input type="checkbox"/> BW vent termination min 12 ft. from base of furnace _____	2427.6.5	802.6.1.2
<input type="checkbox"/> Vented spacer header of first floor & single story _____	2436.1	907.1.2
<input type="checkbox"/> Closed firestop spacers AMI at subsequent ceilings _____	2436.1	907.1.2
Built-in Range/Cooktop Clearances		
<input type="checkbox"/> Vertical clearance to unprotected combustibles 30 in. _____	1901.1	920.3.2
<input type="checkbox"/> Reduced clearance OK if range hood L&L & AMI _____	1901.1	920.3.2#3

EXHAUST SYSTEMS

Exhaust Systems: General	21 IRC	21 UMC
<input type="checkbox"/> Terminate min 3 ft. from LL & building openings _____	1504.3	502.2.1
<input type="checkbox"/> Exhaust ducts require backdraft damper _____	1103.6	504.1.1
<input type="checkbox"/> Exhaust & intake openings require screens 1/4–1/2 in. mesh _____	303.6	502.1
Kitchen Ventilation & Range Hood Ducts		
<input type="checkbox"/> Mechanical exhaust if required by energy codes _____	local	405.4 ³⁶
<input type="checkbox"/> Exhaust rates 100 cfm continuous or 5 ACH intermittent _____	T1505.4.4	405.4 ³⁶
<input type="checkbox"/> Backdraft damper & outdoor termination EXC _____	1503.3	504.1.1
• Ductless hoods OK if other ventilation present _____	1503.3X	504.1X1
<input type="checkbox"/> Range ducts metal w/ smooth interior surface _____	1503.3&4	504.3

CLOTHES DRYERS

General	21 IRC	21 UMC
<input type="checkbox"/> L&L ductless (condensing) dryers OK per L&L _____	1502.2X	504.1X2
<input type="checkbox"/> Closet installation min 100-sq.-in. make-up air opening _____	local	504.4.1
Exhaust Ducts (IRC: Electric, UMC: All Dryer Exhaust Ducts)		
<input type="checkbox"/> Shield plates if < 1/4 in. from framing surface _____	1502.5	n/a
<input type="checkbox"/> Exhaust must be independent of other systems _____	1502.2	504.2&4
<input type="checkbox"/> Min 4 in. diameter & smooth metal _____	1502.4.1	504.4.2
<input type="checkbox"/> End outdoors in backdraft damper w/ no screens F59 _____	1502.3	504.4
<input type="checkbox"/> Terminate min 3 ft. from other building openings _____	1502.3	504.4
<input type="checkbox"/> Min. 12 1/2-sq.-in. area passageway in terminal F59 _____	1502.3.1	504.4.2
<input type="checkbox"/> Ducts smooth metal, fastener penetrations max. 1/8 in. _____	1502.4.1&2	504.4
<input type="checkbox"/> Duct support intervals not to exceed 12 ft. _____	1502.4.2	MFR
<input type="checkbox"/> Duct not deformed in wall cavity (not OK in 2x4 wall) _____	1502.4.2	504.4.2
<input type="checkbox"/> Male ends of duct joints must point in direction of airflow _____	1502.4.2	504.4
<input type="checkbox"/> IRC: Max length 35 ft., AMI, or power ventilator AMI _____	1502.4.6.1&2	n/a
<input type="checkbox"/> IRC: Power ventilators AMI & per UL 705 _____	1502.4.4	n/a
<input type="checkbox"/> IRC: If equivalent length > 35 ft., pre-concealment inspection & label w/ duct length within 6 ft. of connection F59 _____	1502.4.7	n/a
<input type="checkbox"/> UMC: Max length 14 ft. includes 2 90° turns, deduct 2 ft. for each additional 90° elbow EXC _____	n/a	504.4.2.1
• Booster fan L&L to UL 705 max length AMI of fan MFR _____	∅	504.4.2.1X
Connectors (Transition Ducts)		
<input type="checkbox"/> Transition ducts (flex connectors) L&L to UL 2158A _____	1502.4.3	504.4
<input type="checkbox"/> Flex connectors not concealed, single piece & AMI _____	1502.4.3	504.2.2
<input type="checkbox"/> Flex connectors max 8 ft. (UMC : 6 ft.) F59 _____	1502.4.3	504.2.2

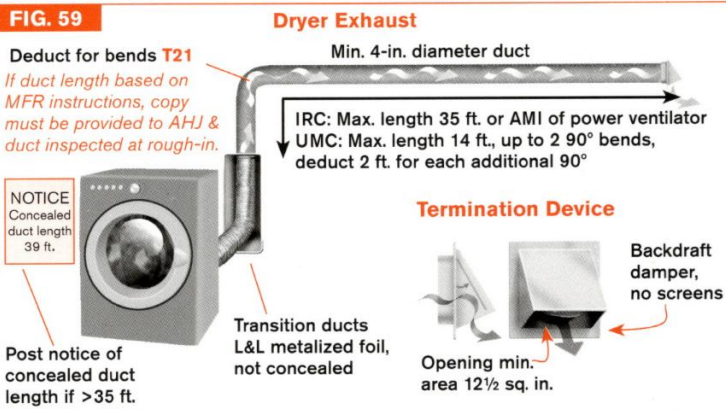
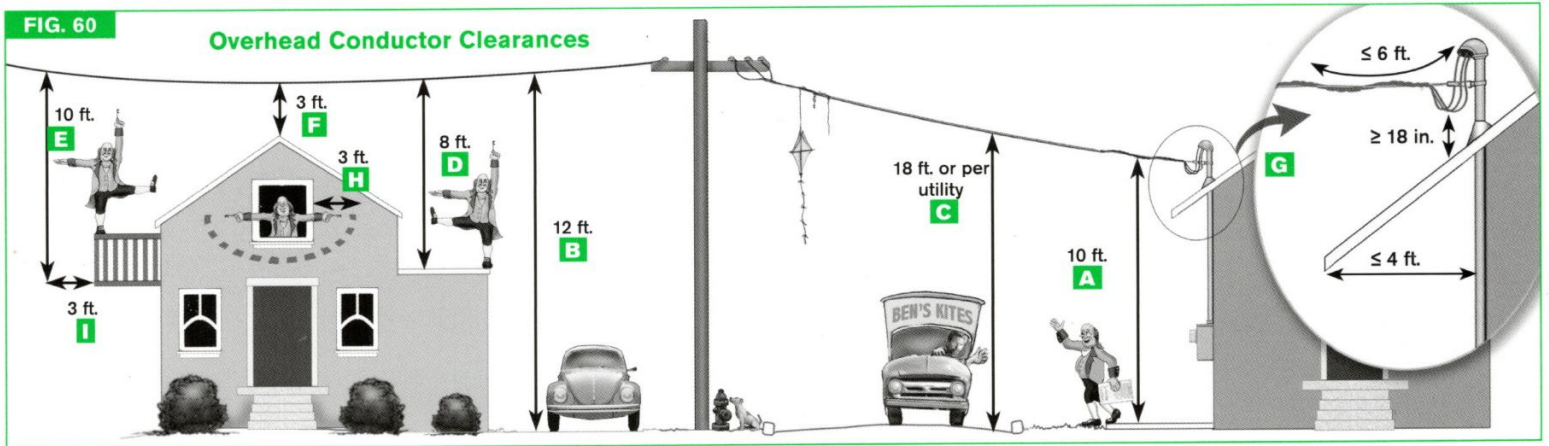

TABLE 21 DRYER FITTING EQUIVALENT LENGTH T1502.4.5.1 & T2439.7.54.1		
Fitting Radius	45° Elbow	90° Elbow
4 in. mitered	2 ft. 6 in.	5 ft.
6 in. smooth	1 ft.	1 ft. 9 in.

IRC Gas Clothes Dryer Exhaust	21 IRC
<input type="checkbox"/> Exhaust must be independent of other systems _____	2439.1
<input type="checkbox"/> End outside in backdraft damper & no screens F59 _____	2439.3
<input type="checkbox"/> Closet requires min 100-sq.-in. make-up air opening _____	2439.5.1
<input type="checkbox"/> Flexible transition connectors L&L & max 8 ft. not concealed & no splices F59 _____	2439.7.3
<input type="checkbox"/> Duct smooth metal, min 4 in. diameter F59 _____	2439.7.1
<input type="checkbox"/> Fastener penetrations max. 1/8 in. _____	2439.7.2
<input type="checkbox"/> Male ends of joints point in direction of airflow, support max 4 ft. O.C. _____	2439.7.2
<input type="checkbox"/> No mixing w/ or passage through other systems _____	2439.3
<input type="checkbox"/> Duct area & termination min 12 1/2-sq.-in. open area F59 _____	2439.3.1
<input type="checkbox"/> No deformation of ducts concealed in walls (not OK in 2x4 wall) _____	2439.7.2
<input type="checkbox"/> Max length AMI or per power ventilator AMI _____	2439.7.4.3
<input type="checkbox"/> Length same as above for electric dryers _____	2439.7.5

FIG. 60

Overhead Conductor Clearances



SERVICES

General	21 IRC	20 NEC
<input type="checkbox"/> All materials & equipment require approval from AHJ	3403.2	110.2
<input type="checkbox"/> Install & maintain L&L equipment AMI	3403.3	110.3B
<input type="checkbox"/> Service capacity \geq max load per T27	3602.1	230.80
<input type="checkbox"/> Single-family dwelling min 100A service rating	3602.3	230.79C
<input type="checkbox"/> All other services w/ >2 circuits min 60A	3603.2	230.79D

Service Riser/Lateral	21 IRC	20 NEC
<input type="checkbox"/> Underground cover depth per utility & T22	3803.1	300.5A
<input type="checkbox"/> Seal underground raceways entering panels	3601.5&3803.6	230.8
<input type="checkbox"/> Warning ribbon \geq 12 in. above buried service conductors	3803.2	300.5D3
<input type="checkbox"/> Only service conductors on mast (no CATV or phone)	3604.5	230.28
<input type="checkbox"/> No couplings between last support & service head	3604.5.1	230.28B
<input type="checkbox"/> Plumbing pipe or fittings prohibited as conduit	3801.2	110.8
<input type="checkbox"/> Secure conduit within 3 ft. of service enclosure	T3802.1	344.30A

Meters & Service Equipment	21 IRC	20 NEC
<input type="checkbox"/> Verify meter height, location, fees w/ utility	3401.3	90.2C
<input type="checkbox"/> Service panel L&L as suitable for service F62	3606.4	230.66A
<input type="checkbox"/> Meter base alone not considered service equipment	3606.4	230.66B
<input type="checkbox"/> Service disconnect readily accessible & inside or outside nearest point of entrance of service conductors	3601.6.2	230.70A1
<input type="checkbox"/> Barriers required over supply terminals & buses F62	3403.3 ³⁷	230.62C ³⁷
<input type="checkbox"/> Max. 1 disconnecting means per service EXC	3601.7 ³⁸	230.71 ³⁸
• 2 to 6 disconnects if each in separate enclosure w/ single main disconnect in each enclosure	3601.7.1 ³⁸	230.71B1 ³⁸
• 2 to 6 panelboards each w/ single main disconnect	3601.7.2 ³⁸	230.71B2 ³⁸
<input type="checkbox"/> Neutral bar bonded in service equipment F62	3607.5	250.24B
<input type="checkbox"/> Emergency disconnect must be outdoors	3601.8 ³⁹	230.85 ³⁹

Surge-Protective Devices (SPD)	21 IRC	20 NEC
<input type="checkbox"/> All services supplying SFD or 2FD require SPD	3606.5 ⁴⁰	230.67A ⁴⁰
<input type="checkbox"/> SPD integral w/ or immediately adjacent to service EXC	3606.5.1 ⁴⁰	230.67B ⁴⁰
• Type 2 SPD each next level distribution equipment	3606.5.1X ⁴⁰	230.67BX ⁴⁰
<input type="checkbox"/> Applicable to replacement service equipment	3606.5.3 ⁴⁰	230.67D ⁴⁰

Service Conductors	21 IRC	20 NEC
<input type="checkbox"/> Not OK to pass through interior of another building	3601.3	230.3
<input type="checkbox"/> Utility may have jurisdiction for outside service conductors	utility	90.2C
<input type="checkbox"/> Size \geq calculated load per T27	3602.1	230.42A
<input type="checkbox"/> Conductor length outside weatherhead per utility	utility	utility
<input type="checkbox"/> Identify (white tape) insulated neutral at each end	3407.1	200.6B
<input type="checkbox"/> Drip loop below weatherhead F60	3605.9.5	230.54F
<input type="checkbox"/> Arrange conductors to prevent water entry into riser	3605.9.6	230.54G
<input type="checkbox"/> Exposed wire listed sunlight-resistant or covered w/ tape or sleeving that is listed as sunlight-resistant	3605.6	310.10D
<input type="checkbox"/> Secure SE cable every 30 in.	3605.7	230.51A
<input type="checkbox"/> Secure SE cable within 12 in. of box & service head	3605.7	230.51A
<input type="checkbox"/> Use wet location type raceway & cable fittings outdoors	3907.2	312.2

Vertical Clearances from Grade F60	21 IRC	20 NEC
<input type="checkbox"/> Service conductors (including drip loop) 10 ft. min above areas accessible only to pedestrians A	3604.2.2	230.24.B
<input type="checkbox"/> 12 ft. above residential property & driveways B	3604.2.2	230.24.B
<input type="checkbox"/> 18 ft. above public streets & tractor trailer parking C	3604.2.2	230.24.B

Vertical Clearances above Roofs F60	21 IRC	20 NEC
<input type="checkbox"/> Setback, location & clearances per utility	3401.3	90.2C
<input type="checkbox"/> Min 8 ft. if slope < 4:12 EXC D	3604.2.1	230.24A
• Min 10 ft. vertical above walkable roof deck E	3604.2.1X1	230.24AX1
<input type="checkbox"/> Min 3 ft. if slope \geq 4:12 EXC F	3604.2.1X2	230.24AX2
• 18 in. above roof OK \leq 4-ft. overhanging eave G	3604.2.1X3	230.24AX3
<input type="checkbox"/> Maintain clearance for 3 ft. past roof edge EXC	3604.2.1	230.24A
• When attached to side of building	3604.2.1X4	230.24AX4
<input type="checkbox"/> 3-ft. clearance OK for guarded/isolated roof areas	3604.2.1X5	230.24AX5
<input type="checkbox"/> Bond metal support to overhead service neutral	3604.6	230.29

Clearances from Building Openings F60	21 IRC	20 NEC
<input type="checkbox"/> Clearance above decks extends 3 ft. past edge I	3604.1	230.9A&B
<input type="checkbox"/> 3 ft. to side or below operable windows H EXC	3604.1	230.9A
• Raceway or cable w/ overall outer jacket	3604.1	230.9A
<input type="checkbox"/> Distance above window per utility or local AHJ	3604.1	230.9AX

FIG. 61

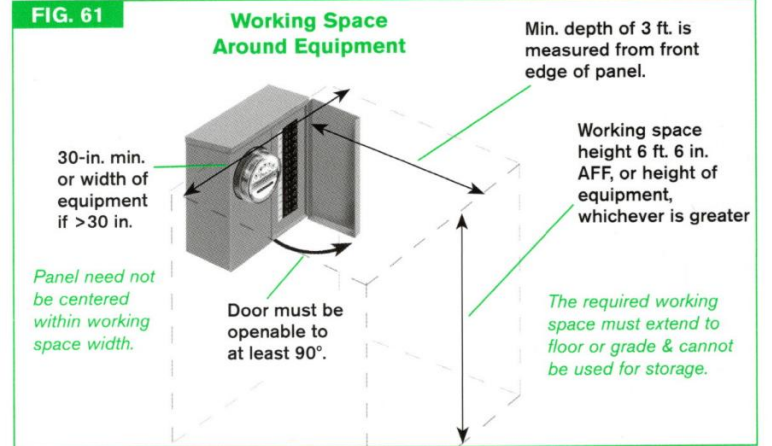

TABLE 22 MIN. COVER REQUIREMENTS ♦ IRC T3803.1 NEC T300.5

Location	UF cable	Rigid metal	PVC	GFCI 15 or 20A circuit	\leq 30V
General	24 in.	6 in.	18 in.	12 in.	6 in.
In trench below 2 in. of concrete	18 in.	6 in.	12 in.	6 in.	6 in.
In raceways under building	0	0	0	0	0
Under min. 4-in. slab no vehicle	18 in.	4 in.	4 in.	6 in.	6 in.
Street	24 in.	24 in.	24 in.	24 in.	24 in.
Driveway	18 in.	18 in.	18 in.	12 in.	18 in.

PANELBOARDS (LOAD CENTERS)

Location and Enclosures	21 IRC	20 NEC
<input type="checkbox"/> Working space min 30 in. wide × 3 ft. deep F61	3405.21	110.26A1&2
<input type="checkbox"/> Working space to floor & min 6-ft. 6-in. height F61	3405.2	110.26A3
<input type="checkbox"/> No panels in clothes closet or bathroom	3705.7	240.24D&E
<input type="checkbox"/> Not to be located over steps of a stairway	3705.7	240.24F
<input type="checkbox"/> Recessed panels flush w/ surface in combustible construction, max 1/4-in. setback in noncombustible construction (steel studs)	3705.7	240.24F
<input type="checkbox"/> Panelboards may not be installed in face-up position	n/a	408.43⁴¹
<input type="checkbox"/> 1/4-in. air space behind surface-mounted metal panels in damp or wet location	3907.2	312.2
<input type="checkbox"/> Circuit directories to distinguish each circuit from all others	3706.2	408.4A
<input type="checkbox"/> Open knockouts & missing cover twist-outs closed	3907.5	110.12A
<input type="checkbox"/> Max height of operating handle of breaker 6 ft. 7 in.	3705.7	240.24A

Wiring and Overcurrent Devices		
<input type="checkbox"/> No grounding of neutral after service EXC F63	3607.2	250.24A5
• Existing separate structure w/ no parallel metal path	3607.3.2	250.32BX
<input type="checkbox"/> Subpanel neutral isolated from enclosure F63	3908.7	408.40
<input type="checkbox"/> Only 1 wire per breaker terminal unless L&L for 2	3406.10	110.14A
<input type="checkbox"/> Each neutral requires individual terminal	3706.4	408.41
<input type="checkbox"/> Overcurrent protection per T25	3705.5	240.4
<input type="checkbox"/> Torque all terminals per labeling	3406.12⁴²	110.14D⁴²
<input type="checkbox"/> Breaker brand and models L&L for panel	3403.3	110.3B
<input type="checkbox"/> Backfed breakers mechanically secured in place EXC	3706.5	408.36D
• Output circuits from listed utility-interactive inverters	n/a	705.12E
<input type="checkbox"/> Handle tie or single handle for multiwire circuits F63	3701.5.1	210.4B

FIG. 64 Grounding Electrodes & Conductors

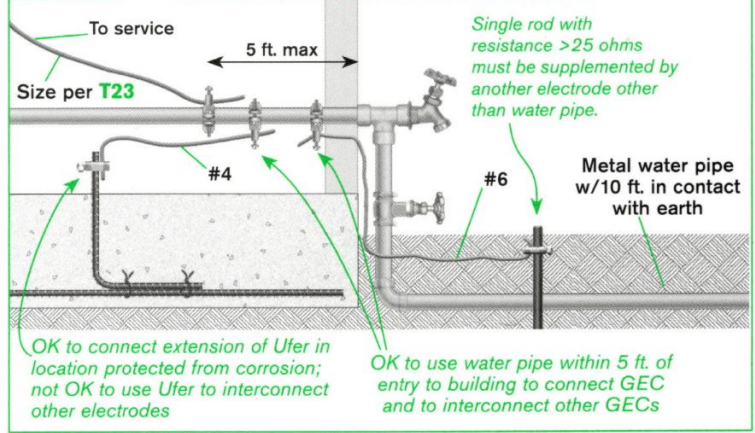

Clamps	21 IRC	20 NEC
<input type="checkbox"/> Buried clamps L&L for direct burial (marked "DB")	3611.1	250.70
<input type="checkbox"/> Cu water tubing clamps L&L for Cu tubing	3611.1	250.70
Grounding Electrode Conductor (GEC)		
<input type="checkbox"/> GEC must connect to incoming service neutral	3607.2	250.24A
<input type="checkbox"/> Protect #8 in raceway or cable armor	3610.2	250.64B
<input type="checkbox"/> #6 following building contour OK w/o protection	3610.2	250.64B
<input type="checkbox"/> Size GEC to T23 EXC	T3603.4	T250.66
• #6 largest required size if dead-ends at rod	T3603.4	250.66A
• #4 largest required size if dead-ends at Ufer	T3603.4	250.66B

FIG. 62 Service Panel **FIG. 63 Subpanel**

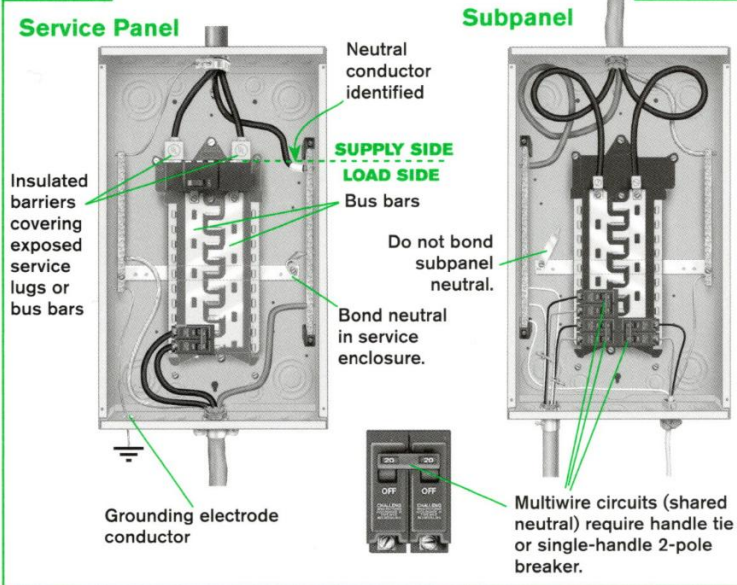

GROUNDING & BONDING

Grounding Electrode System (GES) F64	21 IRC	20 NEC
<input type="checkbox"/> Use metal water pipe if ≥10 ft. in contact w/ soil	3608.1.1	250.52A1
<input type="checkbox"/> Water pipe cannot be only grounding electrode	3608.1.1.2	250.53D2
<input type="checkbox"/> Bond around water meters, regulators, etc.	3608.1.1.2	250.53D1
<input type="checkbox"/> "Ufer" = 20-ft. min #4 rebar or min #4 Cu bare wire in concrete footing, foundation, or pier in contact w/ earth EXC	3608.1.2	250.52A3
• Not required in existing buildings where steel not accessible w/o removal of concrete	3608.1X	250.50X
<input type="checkbox"/> Rod min 8 ft. of soil contact & flush to ground level	3608.1.4.1	250.53G
<input type="checkbox"/> If resistance >25 ohms, install 2nd rod ≥6 ft. from 1st	3608.4	250.53A2&3
<input type="checkbox"/> Each structure w/ >1 branch circuit requires GES	3607.3	250.32A
<input type="checkbox"/> Ufer not OK for interconnection of GECs	3611.5⁴³	250.68C3⁴³
<input type="checkbox"/> Connections to water pipe ≤5 ft. of entry to building	3608.1.1.1	250.68C1

TABLE 23 GROUNDING ELECTRODE CONDUCTOR & EQUIPMENT GROUNDING CONDUCTOR SIZES				TABLE 24	
GEC ♦ IRC T3604.4 NEC T250.66				EGC ♦ IRC T33908.12 NEC T250.122	
Cu Service Wire Size	Al Service Wire Size	Max. Service Rating	Cu GEC	Breaker or Fuse Rating	Size of Cu EGC ^A
≤2	1/0	125	8	15	14
1 or 1/0	2/0 or 3/0	150/175	6	20	12
2/0 or 3/0	4/0 or 250 kcmil	200/225	4	30–60	10
>3/0 to 350 kcmil	>250 kcmil to 500 kcmil	250/300	2	70–100	8
				110–200	6
>350 kcmil to 600 kcmil	>500 kcmil to 900 kcmil	400	1/0	300	4
				400	3

A. Aluminum (Al) EGCs are sized one size larger than Cu.

Bonding	21 IRC	20 NEC
<input type="checkbox"/> Bond all available electrodes (water piping, rod, Ufer)	3608.1	250.50
<input type="checkbox"/> Bond ferrous metal raceways enclosing GEC	3610.3	250.64E
<input type="checkbox"/> If knockouts (KOs) remain or reducing washers used, bond service raceway fittings w/ bonding jumpers	3609.4.4	250.92B
<input type="checkbox"/> If no concentric KOs, use bonding locknuts	3609.4.4	250.92B
<input type="checkbox"/> Bond all metal piping systems capable of becoming energized (hot, cold & gas) at an accessible location	3609.6&7	250.104A&B
<input type="checkbox"/> EGC of equipment may be used to bond gas	3609.7	250.104B

Intersystem Bonding		
<input type="checkbox"/> Provide accessible external L&L terminal bar w/ min 3 terminals to bond phone & CATV, min #6 F47	3609.3.1	250.94A
<input type="checkbox"/> Bar shall not interfere w/ opening service enclosure	3609.3.1	250.94A

Equipment Bonding & Grounding		
<input type="checkbox"/> Wire EGCs sized per T24	3908.13	250.122A
<input type="checkbox"/> EGC must provide effective ground-fault current path	3908.4	250.4A5
<input type="checkbox"/> Earth is not an effective ground-fault current path	3908.5	250.4A5
<input type="checkbox"/> RMC, IMC, EMT, AC cable armor, electrically continuous raceways & surface metal raceways OK as EGC	3908.8	250.118
<input type="checkbox"/> Remove paint from contact surfaces of grounding equipment unless using threaded fittings listed for grounding	3908.18	250.12

TABLE 25 MIN. WIRE SIZE IRC ♦ 3603.1 & T3705.1 NEC 310.15

Fuse or Breaker	Branch Circuits or Feeders AWG Wire Size ^A		Service Conductors AWG Wire Size ^B	
	Cu	Al	Cu	Al
15	14	12	n/a	n/a
20	12	10	n/a	n/a
30	10	8	n/a	n/a
40	8	6	n/a	n/a
50	6	4	n/a	n/a
60	6	4	n/a	n/a
70	4	3	n/a	n/a
80	3	2	n/a	n/a
90	3	1	n/a	n/a
100	2	1/0	4	2
110	2	1/0	3	1
125	1	1/0	2	1/0
150	1/0	2/0	1	2/0
175	2/0	3/0	1/0	3/0
200	3/0	4/0	2/0	4/0
225	4/0	250kcmil	3/0	250kcmil
400	500kcmil	(2)250kcmil	400kcmil	600kcmil

A. Branch circuit & feeder wire sizes are based on not more than 3 current-carrying conductors in a race-way or cable & w/o temperature corrections. Conductors #1 & smaller or connected to breakers 100 amps or less are based on a 60°C ampacity. Larger conductors & breakers are based on 75°C.
 B. Service conductors based on 75°C rating & 83% of ampacity per IRC 3603.1 & NEC 310.15(B)(7).

BRANCH CIRCUITS

- Required Branch Circuits** **21 IRC** **20 NEC**
- Min 2-20A small appliance (S.A.) circuits for recepts in kitchen, breakfast room, dining room & pantry EXC _____ 3703.2 210.11C1
 - Appliances (refrigerator) on ≥15A individual circuits 3703.2X 210.52B1X2
 - Min 1-20A circuit dedicated for laundry recepts _____ 3703.3 210.11C2
 - Min 1-20A circuit dedicated for required bath recepts 3703.44 210.11C344
 - Min 1-20A circuit dedicated for garage general-purpose recepts (not to supply lighting or garage door opener) _____ 3703.545 210.11C445
 - Central heating requires individual circuit _____ 3703.1 422.12
 - Individual circuit for cord/plug-connected range hood _____ 4101.3 422.16B4
 - Interior living space: typical 1 circuit per 500 sq. ft. _____ 3703.6 210.11A
- Restrictions on Required Circuits** ("Outlet" = light or receptacle)
- No other outlets on small appliance circuits EXC _____ 3901.3.1 210.52B2
 - Range ignition recep or dedicated clock recep _____ 3901.3.1X 210.52B2X
 - No other outlets on bath recep circuits EXC _____ 3703.4 210.11C3
 - Separate 20A circuit may serve all outlets in 1 bath 3703.4X 210.11C3X
 - Only laundry recepts on laundry circuit (no lights) _____ 3703.3 210.11C2

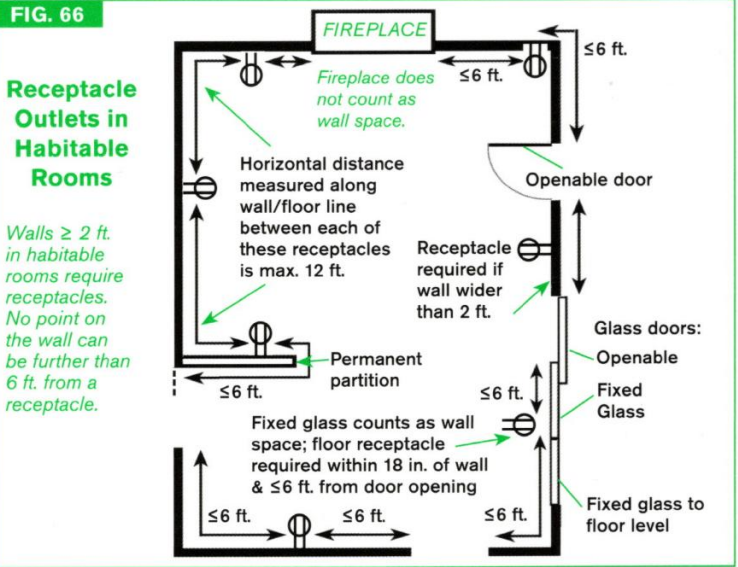
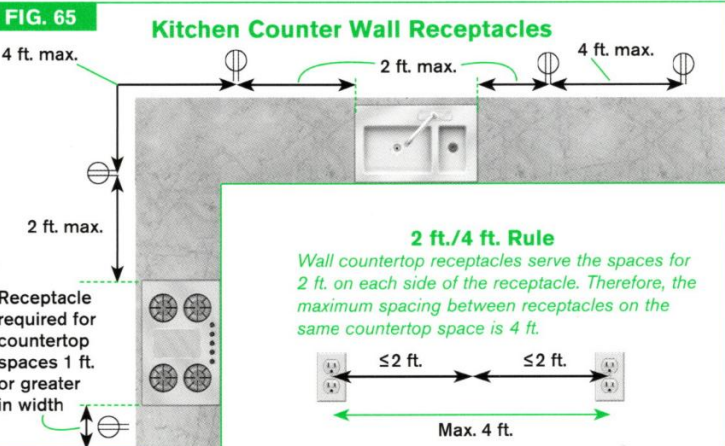

RECEPTACLE OUTLETS

- Receptacle Ratings & Controls** **21 IRC** **20 NEC**
- 15A recepts OK on 15A or 20A circuits _____ 4002.1.1 21Q.21B3
 - 20A recepts only OK on 20A circuits _____ 4002.1.2 21Q.21B3
 - No dimmers controlling switched recepts _____ 4001.1.2 404.14E
 - Recepts required below tamper-resistant (TR) _____ 4002.1.4 406.12
- Entries, Hallways & Habitable Rooms**
- Any wall ≥ 2 ft. in habitable room requires recep F66 _____ 3901.2.2 210.52A2
 - Recep serves wall space for 6 ft. from recep F66 _____ 3901.2.1 210.52A1
 - Switched recepts don't count unless "half hot" _____ 3901.1 210.52
 - No electric baseboard heaters under recepts _____ 3901.1 210.52
 - Hallway ≥ 10 ft. requires recep _____ 3901.10 210.52H
 - Foyers >60 sq. ft. require recepts in each wall ≥ 3 ft. _____ 3901.1.1 210.52I
- Kitchen, Dining Room & Pantry**
- All countertop & wall recepts on 20A S.A. circuits _____ 3901.3 210.52B1
 - Kitchen countertops ≥ 12 in. wide require recep EXC _____ 3901.4.1 210.52C1
 - Recepts behind corner sink if space ≥ 18 in. deep _____ 3901.4.1X 210.52C1X
 - No point along counter > 24 in. from recep F65,66 _____ 3901.4.1 210.52C1
 - Max. 20 in. above or 12 in. below countertop; max. 6-in. counter projection above recep on face of cabinet _____ 3901.4.346 210.52C346
 - Listed pop-up recepts OK in countertop surface _____ 3901.4.3 210.52C3
 - Islands & peninsulas min. one recep first 9 sq. ft. plus 1 for each additional 18 sq. ft. or fraction thereof _____ 3901.4.247 210.52C247
 - Peninsulas measured from connected wall _____ 3901.4.2 210.52C2
 - Min. 1 recep within 2 ft. of end of peninsula _____ 3901.4.247 210.52C247
- Bathroom**
- Recep within 3 ft. of edge of each basin on wall or side or face of cabinet ≤ 12 in. from top of basin or countertop _____ 3901.6 210.52D
 - Listed pop-up recepts OK in countertop surface _____ 3901.6 210.52D
 - No recepts in zone extending 3 ft. horizontally & 8 ft. vertically above top of tub rim or shower threshold EXC _____ 4002.1148 406.9C48
 - If room too small to comply, install opposite tub or shower on farthest wall within room _____ 4002.11X48 406.9CX48
- Laundries, Basements & Garages**
- Min. 1 laundry recep on 20A circuit (no lights on same) _____ 3901.8 210.52F
 - Min. 1 recep each vehicle bay max. 5½ ft. AFF _____ 3901.9 210.52G1
 - Min. one recep each accessory building w/ power _____ 3901.9 210.52G2
 - Min. one recep each unfinished basement area _____ 3901.9 210.52G3
- Outdoor**
- Damp or wet location recepts listed weather-resistant 4002.8&9 406.9A&B1
 - Weatherproof cover in damp location (e.g.: carport) _____ 4002.8 406.9A
 - Wet location in-use covers must be rated "extra duty" _____ 4002.9 406.9B1
 - Recepts front & rear of dwelling & ≤ 6½ ft. above grade _____ 3901.7 210.52E1
 - Balconies, decks & porches within 4 in. horizontally of dwelling min 1 recep max. 6½ ft. above walking surface _____ 3901.7 210.52E349

GFCI & AFCI PROTECTION

GFCI Receptacles Rated 125–250V⁵⁰	21 IRC	20 NEC
<input type="checkbox"/> All bathroom recepts _____	3902.1	210.8A1
<input type="checkbox"/> All 15A & 20A garage & accessory building recepts _____	3902.2	210.8A2
<input type="checkbox"/> All outdoor recepts EXC _____	3902.3	210.8A3
• Non-readily accessible deicing circuit recep _____	3902.3X	210.8A3X
<input type="checkbox"/> Recept & lighting in crawlspaces at or below grade _____	3902.4	210.8A4&C
<input type="checkbox"/> All basement recepts EXC _____	3902.5 ⁵¹	210.8A5 ⁵¹
• Recept supplying permanent fire or burglar alarm _____	3902.5X	210.8A5X
<input type="checkbox"/> All recepts serving kitchen countertops _____	3902.6	210.8A6
<input type="checkbox"/> Recept within 6 ft. of top edge of bowl of any sink _____	3902.7 ⁵²	210.8A7 ⁵²
<input type="checkbox"/> Recept within 6 ft. of any tub or shower stall _____	3902.8	210.8A9
<input type="checkbox"/> All laundry area recepts (including 240V dryers) _____	3902.9 ⁵⁰	210.8A10 ⁵⁰
<input type="checkbox"/> Outlets supplying dishwashers _____	3902.11	210.8D
<input type="checkbox"/> Hoists & recepts in boathouses _____	3902.12&13	210.8A8&C

Required AFCI Protection (“Outlet” = recep, light, or smoke alarm)

- Branch circuits w/ outlets or devices in kitchens, family rooms, dining & living rooms, parlors, libraries, dens, bedrooms, closets, laundries, sun & recreation rooms, hallways & similar _____ 3902.17 210.12A
- Replacement recepts in above locations _____ local 406.4D3
- Extensions or modifications of existing circuits serving above locations (can be outlet type at 1st recep) EXC _____ 3902.18 210.12D
- ≤6 ft. of conductor extension w/ no new outlets or devices (panel replacement to nearby location) _____ 3902.18X 210.12DX⁵³
- Must be UL listed “combination type” or type w/ similar effectiveness; see *Code Check Electrical* for complete list _____ 3902.17 210.12A

APPLIANCES

Allowable Disconnecting Means	21 IRC	20 NEC
<input type="checkbox"/> Branch circuit breaker in sight or equipped w/ locking hasp that remains in place w/ lock removed F67 _____	T4101.5	422.31A
<input type="checkbox"/> Accessible cord/plug OK for appliances listed for cords _____	T4101.5	422.33A
<input type="checkbox"/> Accessible factory-installed separable connector _____	T4101.5	422.33A
<input type="checkbox"/> Unit switch that opens all ungrounded conductors _____	T4101.5	422.34

FIG. 67 Breaker Lockout Hasp

Hasp for lockable breaker must remain in place with or without lock installed.

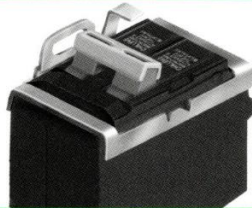

Kitchen	21 IRC	20 NEC
<input type="checkbox"/> Range/oven ≥8.75kW min 40A branch circuit _____	3702.9.1	210.19A3
<input type="checkbox"/> Disposer cord 18–36 in. _____	T4101.3	422.16B1
<input type="checkbox"/> Compactor cord 36–48 in. (measure from back) _____	T4101.3	422.16B1
<input type="checkbox"/> DW cords 36–78 in. (measure from back), recep in adjacent cabinet (not behind DW) & provide grommet to protect cord _____	4101.3 ⁵⁴	422.16B ⁵⁴

Central Furnace & Baseboard Heaters

- Central furnace must be on individual circuit _____ 3703.1 422.12
- Disconnect within sight of furnace _____ T4101.5 422.31B
- Cord & plug connection not OK unless AML _____ 4101.3 422.16A
- Recept in baseboard heaters not on heater circuit _____ 3901.1 424.9

Water Heaters & Space Heating

- Circuit min 125% of nameplate rating _____ 3702.10 422.13
- In-sight or lockable breaker or switch required **F67** _____ T4101.5 422.31B
- NM cable not suitable for direct connection to WH _____ 3802.3 334.15

Paddle Fans

- Independent support or listed fan boxes required _____ 3905.8 422.18
- Listed box system max 70 lb., rating marked if > 35 lb. _____ 3905.8 314.27C
- Boxes in locations acceptable for paddle fans L&L as fan support or provide access to framing for pass-through box _____ 3905.8⁵⁵ 314.27C⁵⁵

Window/Wall Air Conditioners

- Max cord length 120V = 10 ft., 240V = 6 ft. _____ n/a 440.64
- Cord/plug units require AFCI or LCDI in cord or plug cap _____ n/a 440.65

Central Air Conditioning

	21 IRC	20 NEC
<input type="checkbox"/> Central AC wire & breaker/fuse size per nameplate _____	3702.11	440.4B
<input type="checkbox"/> Disconnect in sight of condenser F68 _____	T4101.5	440.14
<input type="checkbox"/> Working space required in front of disconnect F68 _____	3405.2	110.26A
<input type="checkbox"/> GFCI protection required _____	n/a	210.8F ⁵⁶

FIG. 68

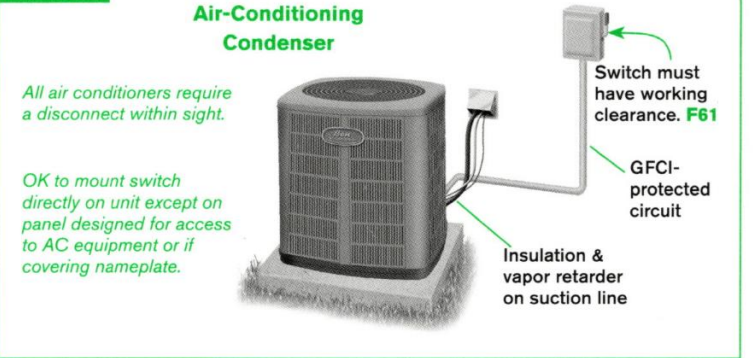

LIGHTING OUTLETS

Required Locations

	21 IRC	20 NEC
<input type="checkbox"/> Wall-switch controlled lighting required in habitable rooms, kitchens & bathrooms EXC _____	3903.2	210.70A1
• Switched recep OK exc in kitchens & bathrooms _____	3903.2X1	210.70A1X
<input type="checkbox"/> Hallways, stairways & garages _____	3903.3	210.70A2
<input type="checkbox"/> Outside exterior doors w/ grade-level access EXC _____	3903.3	210.70A2
• Not required at garage vehicle door _____	3903.3	210.70A2

Switching

- Switches shall be listed & used within their ratings _____ 3403.3 404.14⁵⁷
- Mounting screws 6-32 machine screws or AMI per L&L _____ 4001.10 404.10B
- All switching in ungrounded (hot) conductors _____ 4001.8&9 404.2A&B
- Neutral required at box in habitable rooms, hallways, stairways, and bathrooms or if switch includes auto controls _____ 4001.15 404.2C
- Switch at each stair level if >6 steps _____ 3903.3.1 210.70A2

Bath

- No pendant, track, or suspended lights or paddle fans <8 ft. above & 3 ft. to side of top of tub rim or shower threshold _____ 4003.11 410.10D
- Luminaires <8 ft. above footprint of tub/shower L&L for damp or wet locations if subject to shower spray _____ 4003.11 410.10D

Recessed Lights

- Non-IC rated ½ in. from combustibles _____ 4004.8 410.116A
- Non-IC rated 3 in. from insulation _____ 4004.9 410.116B
- Type IC OK in contact w/ insulation & combustibles _____ 4004.8&9 410.116A2

Clothes Closet

- No open incandescent bulb fixtures _____ 4003.12 410.16B
- Storage area = 24 in. from wall to 6 ft. or height of clothes rod; above rod = 12 in. or shelf width to ceiling **F69** _____ 4003.12 410.2
- Clearances to storage per **F69** _____ 4003.12 410.16C

FIG. 69

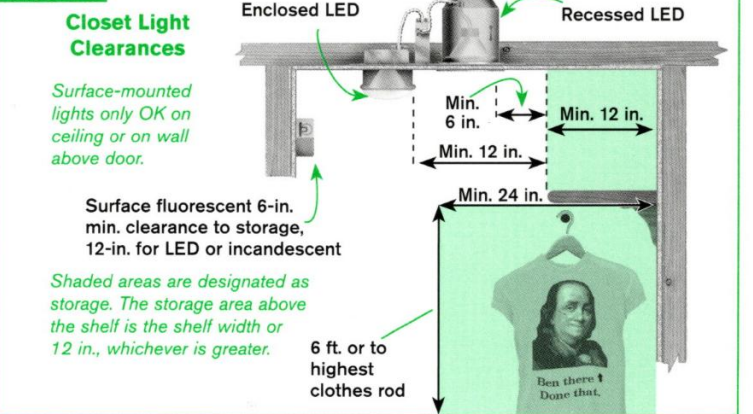

CABLE SYSTEMS

General Rules for NM, UF, SE & AC 21 IRC 20 NEC

- Exposed cables closely follow building surface or on running boards (e.g.: in basement next to load center) _____ 3802.3.1 3XX.15*
 - Support intervals max. 4½ ft. & within 12 in. of box EXC T3802.1 334.30
 - ≤8 in. from single-gang plastic box w/o cable clamp T3802.1 314.17B2X
 - Max cable length between cable entry & support 18 in. _____ n/a 334.30⁵⁸
 - Nail plate if cable < 1¼-in. setback to face of framing T3802.1 300.4A, D
 - Protect cables where below 7 ft. in attics (only within 6 ft. of attic access opening if no permanent stair) _____ 3802.2.1 334.23⁵⁹
 - Cable secured to box EXC _____ T3802.1 314.17B2
 - NM secured to framing ≤8 in. of single-gang box 3905.3.2X 314.17B2X
 - Clamps & cable ties per L&L _____ 3403.3 110.3B
 - No sharp bends (bend radius min 5× cable diameter) _____ 3802.5 3XX.24*
- * The NEC uses a parallel numbering system. The subsection for support is .30; the articles for various cable types are: NM=334, UF=340, SE=338, AC=320.

Nonmetallic Sheathed Cable (NM) F74

- Normally dry locations only _____ T3801.4 334.10A
- Cables ≤#10 require bored holes or running board attached to bottom of joists in crawlspace or basement _____ 3802.4 334.15C
- Conduit or tubing OK as protection on unfinished basement walls if insulating bushing at entry of cable to raceway, sheathing on cable inside conduit & ¼ in. of sheathing into box _____ 3802.4 334.15C
- NM never suitable as flexible cord or w/ plug _____ 3403.3 110.3B
- Listed bushing or grommet through steel studs _____ T3802.1 300.4.B1
- Min ¼ in. of sheathing into boxes _____ 3905.3.1 314.17B2
- Derate if >2 cables in fireblocked wood-frame hole _____ 3705.4.4 334.80

Underground Feeder Cable (UF) F70

- Follow NM rules when used as interior wiring _____ T3802.1 340.10#4
- Protect cable emerging from ground from 18 in. below grade to 8 ft. above grade where exposed _____ 3803.3 300.5D1

Service Entrance Cable (SE) F71

- As service p. 25, as branch see "General" & "NM" _____ T3802.1 338.10
- Feed to subpanel requires insulated neutral F63 _____ 3607.2 338.10B
- Follow NM rules when used as interior wiring _____ 3705.4.5 338.10B4

Armored Cable (AC) "BX"

- Dry locations only _____ T3802.1 320.23
- Supports ≤4½-ft. intervals & within 12 in. of box _____ T3802.1 330.30B&C
- Anti-short bushings ("redheads") required _____ 3403.3 320.40

Metal-Clad Cable (MC) F75

- Wet or buried location OK if jacketed & L&L for same _____ T3801.4 330.10A
- Supports ≤6-ft. intervals & within 12 in. of box _____ T3802.1 330.30B&C
- Secure to boxes & cabinets w/ fittings listed for MC _____ 3403.3 330.6

FIG. 70 UF Cable



FIG. 74 NM Cable



FIG. 71 SE Cable



FIG. 75 MC Cable



FIG. 72 Flex with "Jake" & Clamp Fittings



FIG. 76 Liquidtight Flex



FIG. 73 Rigid PVC Conduit



RACEWAYS

General 21 IRC 20 NEC

- Box & conduit body covers to remain accessible _____ 3905.10 314.29
 - No common plastic boxes w/ metal raceways _____ 3905.3 314.3
 - No splices in small or short radius conduit bodies _____ 3905.12.3 314.16C
 - Max 360° of bends between pull points F77 _____ T3802.1 3XX.26*
 - Underground raceways considered a wet location _____ 3803.10 300.5B
 - Interior of above-ground exterior raceways also considered a wet location; conductors must be rated for same _____ 3802.8 300.9
 - Max fill 40% for > 2 conductors in conduit or tubing T26 _____ 3904.6 9 T1
- * The NEC uses a parallel numbering system. The subsection for bends is .26; the raceway articles are: RMC=344, IMC=342, FMC=348, LPMC=350, PVC=352, EMT=358.

FIG. 77

No more than the equivalent of 4 quarter bends (360°) allowed between pull points

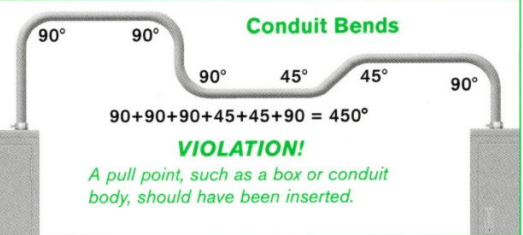

Electrical Metallic Tubing (EMT) F78 21 IRC 20 NEC

- Kinks in pipe not permitted _____ 3802.5 358.24
- Direct burial if suitable protection approved for the condition, buried aluminum EMT requires supplemental protection T3801.4 358.10B1
- Support every 10 ft. & within 36 in. of boxes _____ T3802.1 358.30A
- Listed wet location fittings & connectors in wet locations _____ T3801.4 358.42
- Not allowed as support for boxes or luminaires _____ 3906.8.4 358.12

FIG. 78

EMT "Thinwall"



Flexible Metal Conduit (FMC) F72 21 IRC 20 NEC

- Not OK in wet locations _____ T3801.4 348.12
- Support every 4½ ft. & 12 in. from box EXC _____ T3802.1 348.30
 - Sizes ≤1¼ in. requiring flexibility within 3 ft. max _____ T3802.1 348.30X
- EGC required unless length ≤6 ft. & circuit ≤20A _____ 3908.9.1 250.118
- EGC required if subject to vibration or flexibility _____ 3908.9.1 348.60
- Angle connectors not concealed _____ n/a 348.42

Liquidtight Flexible Metal Conduit (LFMC) F76

- Same as flex except OK for wet locations _____ T3801.4 350.10
- OK for direct burial if L&L for same _____ T3801.4 350.10

Rigid PVC Conduit F73

- Schedule 80 OK to protect NM from damage _____ 3802.3.2 334.15B
- Not OK to support boxes other than conduit bodies _____ 3906.8.4 352.12B
- Expansion fittings if seasonal length change >¼ in. _____ n/a 352.44

TABLE 26 EMT FILL IRC T3904.6(1) & NEC ANNEX TC.1

Size AWG kcmil	Number of Conductors in THHN, THWN, THWN-2							Size AWG kcmil	Number of Conductors in XHHW (Compact Stranding) Annex Table C.1(A)					
	•	½	¾	1	1¼	1½	2		•	½	¾	1	1¼	1½
14	12	22	35	61	84	138	14	-	-	-	-	-	-	-
12	9	16	26	45	61	101	12	-	-	-	-	-	-	-
10	5	10	16	28	38	63	10	-	-	-	-	-	-	-
8	3	6	9	16	22	36	8	3	5	8	15	20	34	
6	2	4	7	12	16	26	6	1	4	6	11	15	25	
4	1	2	4	7	10	16	4	1	3	4	8	11	18	
3	1	1	3	6	8	13	3	-	-	-	-	-	-	
2	1	1	3	5	7	11	2	1	1	3	6	8	13	
1	1	1	1	4	5	8	1	1	1	2	4	6	10	
1/0	1	1	1	3	4	7	1/0	1	1	1	3	5	8	
2/0	0	1	1	2	3	6	2/0	1	1	1	3	4	7	

TABLE 27 LOAD CALCULATIONS IRC T3704.2(1) NEC 220.40		
General Lighting & Receptacle Loads		
Sq. ft. x 3VA		
Small Appliance & Laundry Loads		
2 small appliance circuit	3,000	
Laundry circuit	1,500	
Subtotal including general lighting, small appliance & laundry		
First 3,000VA of subtotal @ 100%	3,000	3,000
Balance of subtotal @ 35%		x .35 =
Special Appliance Loads		
Range	8,000 up to 12kW nameplate	
Dryer	5,000 (or nameplate if greater)	
Heating or Air Conditioning @ 100%		
Appliances Fastened in Place		
WH		
Microwave		
DW		
Disposer		
Other		
Subtotal		
< 4 appliances $\geq \frac{1}{4}$ hp ⁹⁰ & fastened in place, enter subtotal @100%		
If 4 or more such appliances, enter subtotal x 75%		
Largest motor x 25% (if not included in AC nameplate calculation)		
Total load		
Total load + 240V = SERVICE AMPS		

BOXES

General	21 IRC	20 NEC
<input type="checkbox"/> Repair wallboard side gaps > 1/8 in. to outlet box F79	3906.6	314.21
<input type="checkbox"/> Outlet box flush w/ combustible surface F79	3906.5	314.20
<input type="checkbox"/> Max 1/4 in. from noncombustible surface (drywall) F79	3906.5	314.20
<input type="checkbox"/> Boxes & conduit openings must remain accessible	3905.10	314.29
<input type="checkbox"/> Min 6 in. free conductor in box min 3 in. past face	3406.11.3	300.14
<input type="checkbox"/> Covers required (box covers or face plates)	3906.9	314.28C

FIG. 79

Bad Box Placement

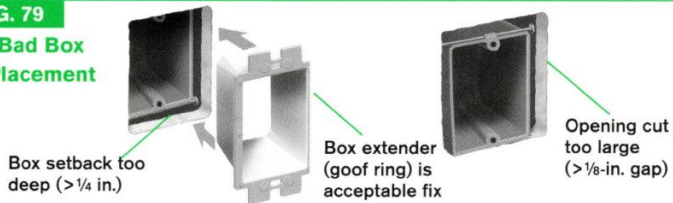

Box Fill

<input type="checkbox"/> Count each conductor exiting box EXC T28	3905.12.2.1	314.16B1
• Wires passing straight through count as 1	3905.12.2.1	314.16B1
<input type="checkbox"/> Looped wires > 12 in. passing through = 2	3905.12.2.1	314.16B1
<input type="checkbox"/> Do not count pigtailed connections to devices	3905.12.2.1	314.16B1
<input type="checkbox"/> Count devices as 2 based on connected wire size	3905.12.2.4	314.16B4
<input type="checkbox"/> Plastic boxes require marking w/ box volume	3905.12.1.2	314.6A2
<input type="checkbox"/> 4-in. pancake box only OK as end of 14/2 run	3905.12	314.16B
<input type="checkbox"/> 18-cu.-in. boxes w/ devices too small for 3 x 12/2 NM cable (min box would be 20.25 cu. in. for those 3 cables)	3905.12	314.16B

TABLE 28 BOX FILL WORKSHEET IRC 3905.12 NEC 314.16			
Item	Size	#	Total
#14 conductors exiting box	2.00		
#12 conductors exiting box	2.25		
#10 conductors exiting box	2.50		
#8 conductors exiting box	3.00		
#6 conductors exiting box	5.00		
Devices: 2x connected conductor size			
Largest EGC—if ≤ 4 , count only one		1	
Additional EGCs add 1/4 for each ⁶¹			
Internal clamps—one based on largest wire present		1	
Fixture fittings—one for each type based on largest wire			
TOTAL			

HYDROMASSAGE TUBS

General F80	21 IRC	20 NEC
<input type="checkbox"/> Equipment accessible w/o damaging building finish	4209.4	680.73
<input type="checkbox"/> Cord & plug connection receps ≤ 1 ft. from opening	4209.4	680.73
<input type="checkbox"/> Provide individual branch circuit & GFCI protection	4209.2	680.71
<input type="checkbox"/> Solid #8 Cu bond EXC	4209.5	680.74A
• Small conductive surfaces such as jets & towel bars	4209.5X2	680.74AX1
• Double-insulated motors	4209.5X1	680.74AX2

FIG. 80

Hydromassage Tub (Whirlpool)

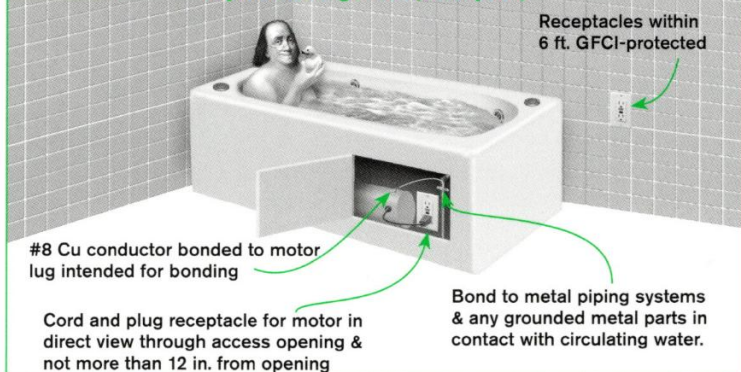

SWIMMING POOLS & SPAS

General	21 IRC	20 NEC
<input type="checkbox"/> Service drop above or within 10 ft. horizontal of pool requires clearance of 22 1/2 ft. in any direction from water	T4203.7	T680.9A
<input type="checkbox"/> Wiring under pool only OK if supplying pool equipment	4203.8	680.11B
<input type="checkbox"/> Underground wiring within 5 ft. RMC, IMC, PVC, or MC, LFMC & LFNC that is L&L for direct burial use	4203.8	680.11A
<input type="checkbox"/> GFCI for all pump motors, including replacements	4203.1.4 ⁶²	680.21C ⁶²
<input type="checkbox"/> Corrosive environment feeders RMC, IMC, PVC, LFNC	T4202.1	680.25A
<input type="checkbox"/> Feeders in corrosive environments min. #12 insulated EGC	4205.6	680.25A

Receptacles

<input type="checkbox"/> Min 1 recep ≥ 6 ft. & ≤ 20 ft. from pool walls	4203.1.3	680.22A1
<input type="checkbox"/> Recept ≤ 20 ft. from pool walls GFCI-protected except where cord would have to pass through wall, door, or window	4203.1.4	680.22A4

Area Lighting Outlets

<input type="checkbox"/> Lights ≥ 12 ft. above water if ≤ 5 ft. horizontal from pool	4203.4.1	680.22B1
<input type="checkbox"/> Indoor pool 7 1/2 ft. above water OK if enclosed & GFCI	4203.4.2	680.22B2

Bonding & Grounding

<input type="checkbox"/> Provide conductive perimeter surface 3 ft. beyond pool & 4-6 in. below subgrade for bonding	4204.2	680.26B2
<input type="checkbox"/> Bond pool shell, perimeter surface 3 ft. beyond pool shell, metal parts & fittings, light forming shell & all metal ≤ 5 ft. of pool	4204.2	680.26B
<input type="checkbox"/> Bond to pool water w/ min 9-sq.-in. contact area	4204.3	680.26C
<input type="checkbox"/> Bonding wire min solid #8 Cu	4204.2	680.26B
<input type="checkbox"/> Pool light EGCs unspliced except on terminals	4205.2	680.23F2
<input type="checkbox"/> Branch circuit EGCs min #12	4205.2	680.23F2

Underwater Lighting

<input type="checkbox"/> GFCI-protected or low-voltage (≤ 15 V AC, ≤ 30 V DC)	4206.4	680.23A3
<input type="checkbox"/> Top of light min 18 in. below water level	4206.4.2	680.23A5
<input type="checkbox"/> PVC to underwater lights min #8 insulated bond wire	4205.3	680.23B2
<input type="checkbox"/> Encapsulate bonding conductor on forming shell	4205.3	680.23B2
<input type="checkbox"/> Segregate GFCI-protected raceways from non-GFCI	4206.3	680.23F3
<input type="checkbox"/> Junction box L&L for pool light	4206.9.1	680.24A1
<input type="checkbox"/> Junction box greater of ≥ 4 in. above grade or ≥ 8 in. above max water level & 4 ft. from pool edge	4206.9.1	680.24A2
<input type="checkbox"/> Flush deck boxes OK for low-voltage ≥ 4 ft. pool & potted	4206.9.1	680.24A2c

Hot Tub/Spa

<input type="checkbox"/> Outdoors same rules as swimming pools EXC	4202.1	680.42
<input type="checkbox"/> Bonding not required for L&L outdoor-use package units installed AMI & rim ≥ 28 in. above all perimeter surfaces ≤ 30 in. from unit	4204.4	680.42B
<input type="checkbox"/> Outlets supplying self-contained, packaged, or field-assembled spa/hot tub requires GFCI (including 240V) EXC	4208.1	680.44
• Outlets supplying listed units w/ integral GFCIs	4208.1	680.44A